



Humboldt Bay Municipal Water District Samoa Reservoir Seismic Retrofit Bid Addendum #2

The purpose of this Addendum is to modify the Contract Documents for the subject project. This Addendum shall become part of said Contract Documents.

Bidders shall acknowledge receipt of this Addendum in their bid proposal.

This Addendum addresses the following items and questions:

1. The sign-in sheet from the pre-bid meeting has been attached.
2. See the clouded modifications on the attached S-502.
3. Specification 31 62 99 (Helical Pile Foundation) shall be replaced in its entirety with the attached revised version of the specification.
4. The attached structural calculations that were used for the design of the project have been provided for reference.
5. The following italicized section of the Advertisement for Bids:

Each coating contractor or subcontractor shall submit a Qualifications Statement as a part of their bid, which shall include the following:

- 1. Copy of California Contractor's license*
- 2. Department of Industrial Relations registration number*
- 3. List of a minimum of three completed projects over the last ten years of similar size and complexity to the coating portion of this work. Include the following for each project:*
 - a. Project name and location.*
 - b. Name of owner with contact number.*
 - c. Name of prime contractor with contact number.*
 - d. Name of engineer with contact number.*
 - e. Name of coating manufacturer with contact number.*
 - f. Approximate area (square footage) of coatings applied.*
 - g. Date of completion.*

shall be stricken and replaced in its entirety with the following italicized language:

Each coating contractor or subcontractor shall submit a Qualifications Statement as a part of their bid, which shall include the following:

1. *Copy of California Contractor's license.*
2. *Department of Industrial Relations registration number.*
3. *Written certification that each applicator performing Work on the projects is trained and qualified to perform the Work.*
4. *Written certification from the Contractor that they are qualified to apply the coating system specified.*
5. *Submit list of a minimum of three (3) completed projects over the last 5 years of similar size and complexity to this Work OR written certification from the Coating Manufacturer that the Coating Contractor is pre-qualified and pre-approved to apply the Manufacturer's products. Include for each project (if applicable):*
 - a. *Project name and location*
 - b. *Name of owner with contact number*
 - c. *Name of contractor with contact number*
 - d. *Name of engineer with contact number*
 - e. *Name of coating manufacturer with contact number*
 - f. *Approximate area (square footage) of coatings applied.*
 - g. *Date of completion.*

6. Is the tank shell in sufficient condition to sandblast?

- a. Based on recent steel thickness readings of the tank shell, it is assumed that the steel shell has retained most of its original thickness and is in sufficient condition for sandblasting.

7. Will the Contractor be required to provide temporary containment during sandblasting operations due to the presence of lead?

- a. A Limited Hazardous Materials Survey Report for the site was included as Appendix B to the specifications. The Contractor shall review the lead sampling results summarized in this report and comply with all applicable regulations including, but not limited to, those noted in Specification 02 83 00 (Removal and Disposal of Material Containing Lead).

8. May the Contractor propose an alternative retrofit design solution for the tank foundation in lieu of the current anchor chair and helical screw anchor design?

- a. The tank does not meet current seismic requirements for overturning. The purpose of the designed tank foundation retrofits, including anchor chairs, helical screw anchors, and cast-in-drilled hole (CIDH) piles is to provide sufficient resistance to overturning based on current seismic requirements. This includes design criteria as prescribed in AWWA D100-11 and other design criteria noted in the Sheet General Notes section of Sheet S-001.

The design as shown in the Drawings and described in the Specifications meets all necessary requirements. The Contractor may propose an alternative retrofit design solution after award of the project provided that the design and associated calculations meet the project design criteria noted above and are signed and stamped by a licensed Civil Engineer registered in the State of California. Furthermore, the design footprint shall not exceed the plan view footprint of the existing above-ground 1996 retrofit concrete curb around the tank.

If the Contractor elects to proceed with this process, a foundation retrofit design submittal shall be provided to the Engineer of Record for review and approval after contract award. The submittal shall show the proposed design and demonstrate that the proposed design meets the requirements outlined above. No additional payment shall be made for any design, construction, or any other work the Contractor elects to perform associated with implementing an alternative retrofit design solution. If a Bidder plans to implement an alternative retrofit design solution, their bid shall account for all design, construction, and other work required to execute the alternative solution. If the Engineer of Record determines that the Contractor's proposed design does not adequately demonstrate that it meets the criteria prescribed in AWWA D100-11 or other design criteria noted in the Sheet General

Notes section of Sheet S-001, the Contractor shall construct the project as currently designed without any additional payment.

9. Clarification of the construction sequencing for installing the foundation retrofit at the tank:

- a. As shown on Detail 2/S-502 (with additional detail provided in the image below in this Addendum), there is an existing concrete containment curb underground adjacent to the tank. The containment curb was installed during the original tank construction in 1965, and its purpose is to hold in the oiled sand that is under the tank floor. Additionally, a partially above ground, partially below ground concrete retrofit around the tank was installed in 1996.

Detail 1/S-502 shows a new containment curb to be installed underground outside the existing containment curb and retrofit. The construction sequencing notes on Detail 1/S-502 note that the new containment curb shall be installed prior to any other demolition. The reason for this is that new containment of the oiled sand must be in place prior to compromising the integrity of the existing containment. However, if the Contractor implements an approved alternative design solution for meeting the design criteria (see #8 above) without negating the effectiveness of the existing containment curb, then a new containment curb would not be required.

Note that the current 1996 seismic retrofit will no longer be required after implementation of the retrofit design as shown in the Drawings. Construction Sequencing Note 2 on Detail 1/S-502 notes that the existing retrofit shall be removed above finished grade elevation in its entirety, but that the existing underground concrete shall not be damaged. If the Contractor's proposes an approved alternative design solution that incorporates leaving the existing retrofit intact, then it shall be allowed.

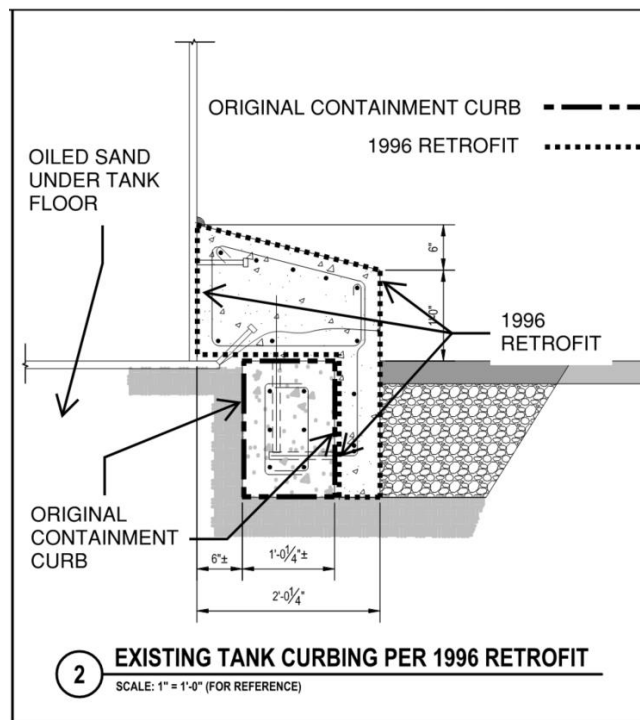

10. The tank has existing side vents at the top of the top tank shell ring as shown in the attached Circumferential Vent Screen Detail. There are 37 vents that are 48" wide by 10" tall, including the frames. The vent screens and all appurtenances used to connect them to the tank shall be removed by the Contractor, and new steel plates shall be welded in to cover the entire opening at each vent location. The new steel plate thickness shall match the existing thickness (anticipated to be approximately 1/4"). The steel plates shall be surface prepped and coated in accordance with the Drawings and Specifications. This work will be paid for under Bid Item 6 (Remove, Relocate, Modify, and/or Replace Miscellaneous Metal, Piping, and Electrical Items at/on Tank).

END OF ADDENDUM

5/21/2024

Date

A handwritten signature in black ink, appearing to read "Just [unclear]", written over a horizontal line.

Signature



**Humboldt Bay Municipal Water District
Samoa Reservoir Seismic Retrofit Project
Pre-Bid Meeting Sign-In Sheet**

Date: May 9, 2024

Location: Samoa Site, Humboldt County, CA

Name	Company/Affiliation	Phone	Email
Nathan Stevens	GHD	(707) 267-2204	nathan.stevens@ghd.com
Sean Alexander	Resource Development Company	(775) 343-9714	salexander@resourcedevelopmentco.com
Mike Clifton	Unified Field Services Corporation	(925) 337-9090	mclifton124@comcast.net
Chad Johnson	Unified Field Services Corporation	(661) 805-8516	chad_johnson@ufsc.us
Mark Benzinger	Mercer-Fraser	(707) 599-6371	mbenzinger@mercerfraser.com
Casey Poff	GR Sundberg	(707) 825-6565	grs@grsinc.biz
Dale Davidsen	HBMWD	(707) 822-2918	supt@hbmwd.com

SECTION 31 62 99

HELICAL PILE FOUNDATION

PART 1 GENERAL

1.01 PURPOSE OF SPECIFICATION

- A. The purpose of this specification is to detail the furnishing of all designs, materials, tools, equipment, labor and supervision, and installation techniques necessary to install Helical Piles as detailed on the drawings, including connection details. This shall include provisions for load testing that may be part of the scope of work

1.02 SCOPE OF WORK

- A. This work consists of furnishing all necessary engineering and design services (if required), supervision, labor, tools, materials, and equipment to perform all work necessary to install the Helical Piles, at the Samoa tank site for Humboldt Bay Municipal Water District (HBMWD) per the specifications described herein, and as shown on the drawings. The Contractor shall install a Helical Pile that will develop the load capacities as detailed on the drawings. This includes provisions for load testing to verify Helical Pile capacity and deflection, if part of the scope of work. The responsibilities and duties of the respective parties for this project are summarized in Table-1.
- B. For the purpose of this Section, Owner is defined as HBMWD, Structural Engineer of Record (SEOR) is defined as GHD, and Contractor is defined as the Prime Contractor or his/her Subcontractors.

Table-1. Tasks and Responsibilities to be Allocated for Helical Pile Work

TASK		RESPONSIBLE PARTY
1	Site Investigation, Geotechnical Investigation, Site Survey, and potential work restrictions	Owner
2	Type of specification, requirement for a pre-contract testing program, and procurement method	Owner
3	Obtaining easements	Owner
4	Overall scope of work, design of the Helical Pile structure – including design loads (vertical, horizontal, etc.), pile locations, and pile spacing and orientation	Contractor/SEOR
5	Definition and qualification of safety factors	Contractor/SEOR
6	Calculation/estimation of allowable structural and/or Helical Pile movement in service (acceptance criteria)	Contractor/SEOR
7	Definition of service life (temporary – months or permanent - years) and required degree of corrosion protection based on site conditions	SEOR
8	Minimum total Helical Pile length, depth to bearing stratum	Contractor
9	Helical Pile components and details	Contractor
10	Details of corrosion protection, if required	Contractor
11	Details of pile connection to structure (e.g., for static and seismic conditions)	Contractor/SEOR

12	Preparation of Helical Pile Shop Drawings and test reports	Contractor
13	Evaluation of test results	Owner
14	Construction methods, schedule, sequencing, and coordination of work	Contractor
15	Requirements of field production control, including logging of installation torque vs. installed depth	Contractor/Owner
16	Supervision of work	Contractor/Owner
17	Long-term monitoring	Owner

1.03 QUALIFICATIONS OF THE HELICAL PILE CONTRACTOR

- A. The Helical Pile Contractor shall be experienced in performing design and construction of Helical Piles and shall furnish all materials, labor, and supervision to perform the work. The Contractor shall be trained and certified by CHANCE Civil Construction or other qualified firm in the proper methods of design and installation of Helical Piles. The Contractor shall provide names of on-site personnel materially involved with the work, including those who carry documented certification from CHANCE Civil Construction or other qualified firm. At a minimum, these personnel shall include foreman, machine operator, and project engineer/manager.
- B. The Helical Pile Contractor shall not sublet the whole or any part of the contract without the express written permission of the Owner.

1.04 DEFINITIONS

- A. A partial list follows.
 1. **Contractor:** The person/firm responsible for performing the Helical Pile work.
 2. **Coupling:** Central steel shaft connection means formed as integral part of the plain extension shaft material. For Type SS & RS Helical Piles, couplings are internal or external sleeves, or hot upset forged sockets.
 3. **Coupling Bolt(s):** High strength, structural steel fasteners used to connect Helical Pile segments together. For Type SS segments, the coupling bolt transfers axial load. For Type RS segments, the coupling bolts transfer both axial and torsional forces.
 4. **Helical Extension:** Helical Pile foundation component installed immediately following the lead or starter section, if required. This component consists of one or more helical plates welded to a central steel shaft of finite length. Function is to increase bearing area.
 5. **Helix Plate:** Generally round steel plate formed into a ramped spiral. The helical shape provides the means to install the helical pile, plus the plate transfers load to soil in end bearing. Helix plates are available in various diameters and thickness.
 6. **HELICAL PULLDOWN® Micropile:** A small diameter, soil displacement, cast-in-place Helical Pile, in which most of the applied load is resisted by the central steel shaft and steel reinforcement, if installed. Load transfer to soil is both end bearing and friction.
 7. **Helical Pile:** A bearing type foundation element consisting of a lead or starter section, helical extension (if so required by site conditions), plain extension

section(s), and a pile cap. A.k.a. helical screw pile, screw pile, helical screw foundation.

8. **Installation Torque(T):** The resistance generated by a Helical Pile when installed into soil. The installation resistance is a function of the soil type, and size and shape of the various components of the Helical Pile.
9. **Lead Section:** The first Helical Pile foundation component installed into the soil, consisting of single or multiple helix plates welded to a central steel shaft. A.k.a. Starter Section.
10. **Pile Cap:** Connection means by which structural loads are transferred to the Helical Pile. The type of connection varies depending upon the requirements of the project and type of Helical Pile material used.
11. **Round Shaft (RS):** Round steel pipe central Shaft elements ranging in diameter from 2-7/8" to 10". A.k.a. Hollow Shaft (Type HS), Type T/C, Type PIF.
12. **Plain Extension:** Central steel shaft segment without helix plates. It is installed following the installation of the lead section or helical extension (if used). The segments are connected with integral couplings and bolts. Plain extensions are used to extend the helix plates beyond the specified minimum depth and into competent load bearing stratum.
13. **Safety Factor:** The ratio of the ultimate capacity to the working or design load used for the design of any structural element.
14. **Square Shaft (SS):** Solid steel, round-cornered-Square central Shaft elements ranging in size from 1-1/4" to 2-1/4". A.k.a. Type SQ.
15. **Torque Strength Rating:** The maximum torque energy that can be applied to the helical pile foundation during installation in soil, a.k.a. allowable, or safe torque.

1.05 ALLOWABLE TOLERANCES

- A. The tolerances quoted in this section are suggested maximums. The actual values established for a particular project will depend on the structural application.
- B. Centerline of Helical Piles shall not be more than 1.25 inches from indicated plan location.
- C. Helical Pile plumbness shall be within 1° of design alignment.
- D. Top elevation of Helical Pile shall be within +1 inch to -2 inches of the design vertical elevation.

1.06 QUALITY ASSURANCE

- A. Helical Piles shall be installed by authorized CHANCE Civil Construction certified Contractor or approved equal. These Contractors shall have satisfied the certification requirements relative to the technical aspects of the product and installation procedures as therein specified. Certification documents shall be provided upon request to the Owner or their representative.
- B. The Contractor shall employ an adequate number of skilled workers who are experienced in the necessary crafts and who are familiar with the specified requirements and methods needed for proper performance of the work of this specification.
- C. All Helical Piles shall be installed in the presence of a designated representative of the Owner unless said representative informs the Contractor otherwise. The designated representative shall have the right of access to any and all field installation records and test reports.

- D. Helical Pile components as specified therein shall be manufactured by a facility whose quality systems comply with ISO (International Organization of Standards) 9001 requirements. Certificates of Registration denoting ISO Standards Number shall be presented upon request to the Owner or their representative.
- E. Manufacturer shall provide a standard one-year warranty on materials and workmanship of the product. Any additional warranty provided by the Contractor shall be issued as an addendum to this specification.
- F. Design of Helical Piles shall be performed by an entity as required in accordance with existing local code requirements or established local practices. This design work may be performed by a licensed professional engineer, a certified CHANCE Civil Construction Contractor, or other qualified designer.

1.07 DESIGN CRITERIA

- A. Helical Piles shall be designed to meet the specified loads and acceptance criteria as shown on the drawings. The calculations and drawings required from the Contractor or Engineer shall be submitted to the Owner for review and acceptance in accordance to Section 3.1 "Construction Submittals".
- B. The allowable working load on the Helical Piles shall not exceed the following values:

- 1. For compression loads:

$$P_{allowc} = 0.4 * f_{yshaft} * A_{shaft}$$

Where: P_{allowc} = allowable working load in compression (kip)

f_{yshaft} = minimum yield strength of central steel shaft (ksi)

A_{shaft} = area of central steel shaft (with corrosion allowance if required) (in.²)

- 2. For tension loads:

$$P_{allowt} = S_{ut} / FS$$

Where: P_{allowt} = allowable working load in tension (kip)

S_{ut} = Min. ultimate tensile strength of central steel shaft segment (at coupling joint) (kip)

FS = factor of safety suitable for application, i.e. temporary or permanent structures

- C. The ultimate structural capacity shall be determined as:

- 1. For compression loads:

$$P_{ultc} = f_{yshaft} * A_{shaft}$$

Where: P_{ultc} = ultimate structural capacity in compression (kip)

f_{yshaft} = minimum yield strength of central steel shaft (ksi)

A_{shaft} = area of central steel shaft (with corrosion allowance if required) (in.²)

- 2. For tension loads:

$$P_{ultt} = S_{ut}$$

Where: P_{ultt} = Ultimate structural capacity in tension (kip)

S_{ut} = Minimum ultimate tensile strength of central steel shaft (kip)

- D. The overall length and installed torque of a Helical Pile shall be specified such that the required in-soil capacity is developed by end-bearing on the helix plate(s) in an appropriate strata(s).
- E. It is recommended that the theoretical end-bearing capacity of the helix plates be determined using HeliCAP® Engineering Software or equal commercially available software. The required soil parameters (c , ϕ , γ , or N-values) for use with HeliCAP® or equal shall be provided in the geotechnical reports. The Owner shall determine the allowable response to axial loads.
- F. Lateral Load and Bending: Where Helical Piles are subjected to lateral or base shear loads as indicated on the plans, the bending moment from said loads shall be determined using lateral load analysis program such as LPILE or equal commercially available software. The required soil parameters (c , ϕ , γ , and k_s) for use with LPILE or equal shall be provided in the geotechnical reports. The Owner shall determine the allowable response to lateral loads. The combined bending and axial load factor of safety of the Helical Pile shall be as determined by the Owner.
- G. Critical Buckling Load: Where Helical Piles are installed into low strength soil, the critical buckling load shall be determined using lateral load analysis program such as LPILE or equal commercially available software, or various other methods. The required soil parameters (c , ϕ , γ , and k_s) for use with LPILE or equal shall be provided in the geotechnical reports.
- H. Expansive Soils: Helical Pile used in areas where expansive soils are present may require the use of special construction methods to mitigate possible shrink/swell effects. Helical Pile shafts should be isolated from the concrete footing if said footing is in contact with the expansive soil.
- I. Down-Drag/Negative Skin Friction: Type SS and Type RS Helical Piles are slender shaft foundation elements and are not practically affected by down-drag/negative skin friction. If Helical Piles with central steel shafts $>4"$ in diameter are used in areas where compressible or decomposing soils overlie bearing stratum, or where expansive or frozen soils can cause pile jacking, Helical Pile shafts should be provided with a no-bond zone along a specified length to prevent load transfer that may adversely affect pile capacity. Alternately, Helical Piles can be provided with sufficient axial load capacity to resist down drag/negative skin friction forces.
- J. The Helical Pile attachment (pile cap) shall distribute the design load (DL) to the concrete foundation such that the concrete bearing stress does not exceed those in the ACI Building Code and the stresses in the steel plates/welds does not exceed AISC allowable stresses for steel members.
- K. Corrosion Protection
 - 1. **Structure Type:** Permanent
 - 2. **Service Life:** 50 years
 - a. Corrosion protection requirements for the various Helical Pile elements shall be provided meeting the requirements of Table-2 in the Appendix for:
 - 3. **Soil:** Aggressive

TABLE-2

CORROSION PROTECTION				
LOADING	TENSION		COMPRESSION	
SOIL	AGGRESSIVE ¹	NON-AGGRESSIVE	AGGRESSIVE ¹	NON-AGGRESSIVE
CENTRAL STEEL SHAFT (Lead Section)	a. Galvanization OR b. Minimum 1/8" corrosion loss on outside	a. Bare steel OR b. Galvanization OR c. Minimum 1/8" corrosion loss on outside	a. Galvanization OR b. Minimum 1/8" corrosion loss on outside	a. Bare steel OR b. Galvanization OR c. Minimum 1/8" corrosion loss on outside
CENTRAL STEEL SHAFT (Extension Section)	a. Galvanization OR b. Epoxy coating OR c. a. or b. + Grout cover ² The Specifier may elect to use a grout case.	a. Bare steel OR b. Galvanization OR c. Epoxy coating	a. Galvanization OR b. Epoxy coating OR c. a. or b. + Grout cover ² The Specifier may elect to use a grout case.	a. Bare steel OR b. Galvanization OR c. Epoxy coating
STEEL PILE CAP	a. Galvanization OR b. Epoxy coating	d. Bare steel OR e. Galvanization OR f. Epoxy coating	c. Galvanization OR d. Epoxy coating	g. Bare steel OR h. Galvanization OR i. Epoxy coating

NOTES:

Lettered items are options.

For guidance on aggressiveness classification, see Table-2 of the Appendix.

1. Corrosion protection shall extend 15'-0 below corrosive material.
2. Minimum 1" in soil. If protective coatings (galvanization, epoxy) are provided in compression, minimum cover may be 0.25" in soil. Grout column can be installed using the HELICAL PULLDOWN® Micropile method.

1.08 GROUND CONDITIONS

- A. The Geotechnical Report, including logs of soil borings as shown on the boring location plan, shall be considered to be representative of the in-situ subsurface conditions likely to be encountered on the project site. Said Geotechnical Report shall be the used as the basis for Helical Pile design using generally accepted engineering judgement and methods.
- B. The Geotechnical Report shall be provided for purposes of bidding. If during Helical Pile installation, subsurface conditions of a type and location are encountered of a frequency that were not reported, inferred and/or expected at the time of preparation of the bid, the additional costs required to overcome such conditions shall be considered as extras to be paid for.

PART 2 REFERENCED CODES AND STANDARDS

Standards listed by reference, including revisions by issuing authority, form a part of this specification section to the extent indicated. Standards listed are identified by issuing authority, authority abbreviation, designation number, title, or other designation established by issuing authority. Standards subsequently referenced herein are referred to by issuing authority abbreviation and standard designation. In case of conflict, the particular requirements of this specification shall prevail. The latest publication as of the issue of this specification shall govern, unless indicated otherwise.

2.01 AMERICAN SOCIETY FOR TESTING AND MATERIALS (ASTM):

- A. ASTM A29/A29M Steel Bars, Carbon and Alloy, Hot-Wrought and Cold Finished.
- B. ASTM A36/A36M Structural Steel.
- C. ASTM A53 Pipe, Steel, Black and Hot-Dipped, Zinc-Coated Welded and Seamless.
- D. ASTM A153 Zinc Coating (Hot Dip) on Iron and Steel Hardware.
- E. ASTM A252 Welded and Seamless Steel Pipe Piles.
- F. ASTM A775 Electrostatic Epoxy Coating
- G. ASTM A193/A193M Alloy-Steel and Stainless Steel Bolting Materials for High Temperature Service.
- H. ASTM A320/A320M Alloy-Steel Bolting Materials for Low Temperature Service.
- I. ASTM A325 Standard Specification for Structural Bolts, Steel, Heat Treated, 120/105 ksi Minimum Tensile Strength.
- J. ASTM A500 Cold-Formed Welded and Seamless Carbon Steel Structural Tubing in Rounds and Shapes.
- K. ASTM A513 Standard Specification for Electric Resistance Welded Carbon and Alloy Steel Mechanical Tubing.
- L. ASTM A536 Standard Specifications for Ductile Iron Castings
- M. ASTM A572 HSLA Columbium-Vanadium Steels of Structural Quality.
- N. ASTM A618 Hot-Formed Welded and Seamless High-Strength Low-Alloy Structural Tubing.
- O. ASTM A656 Hot-Rolled Structural Steel, High-Strength Low-Alloy Plate with Improved Formability.
- P. ASTM A958 Standard Specification for Steel Castings, Carbon, and Alloy, with Tensile Requirements, Chemical Requirements Similar to Wrought Grades.
- Q. ASTM A1018 Steel, Sheet and Strip, Heavy Thickness Coils, Hot Rolled, Carbon, Structural, High-Strength Low-Alloy, Columbium or Vanadium, and High-Strength Low-Alloy with Improved Formability.
- R. ASTM D1143 Method of Testing Piles Under Static Axial Compressive Load.
- S. ASTM D3689 Method of Testing Individual Piles Under Static Axial Tensile Load.

2.02 AMERICAN WELDING SOCIETY (AWS):

- A. AWS D1.1 Structural Welding Code – Steel.
- B. AWS D1.2 Structural Welding Code – Reinforcing Steel.

2.03 AMERICAN SOCIETY OF CIVIL ENGINEERS (ASCE):

- A. ASCE 20-96 Standard Guidelines for the Design and Installation of Pile Foundations.

2.04 DEEP FOUNDATIONS INSTITUTE (DFI):

- A. Guide to Drafting a Specification for High Capacity Drilled and Grouted Micropiles for Structural Support, 1st Edition, Copyright 2001 by the Deep Foundation Institute (DFI).

2.05 SOCIETY OF AUTOMOTIVE ENGINEERS (SAE):

- A. SAE J429 Mechanical and Material Requirements for Externally Threaded Fasteners.

PART 3 SUBMITTALS

3.01 CONSTRUCTION SUBMITTALS

- A. The Contractor or Engineer shall prepare and submit to the Owner, for review and approval, working drawings and design calculations for the Helical Piles intended for use at least 14 calendar days prior to planned start of construction (but note also Paragraph 3.1.8). All submittals shall be signed and sealed by a Registered Professional Engineer currently licensed in the State of California.
- B. The Contractor shall submit a detailed description of the construction procedures proposed for use to the Owner for review. This shall include a list of major equipment to be used.
- C. The Working Drawings shall include the following:
 - a. Helical Pile number, location and pattern by assigned identification number
 - b. Helical Pile design load
 - c. Type and size of central steel shaft
 - d. Helix configuration (number and diameter of helix plates)
 - e. Minimum effective installation torque
 - f. Minimum overall length
 - g. Inclination of Helical Pile
 - h. Cut-off elevation
 - i. Helical Pile attachment to structure relative to grade beam, column pad, pile cap, etc.
- D. The Contractor shall submit shop drawings for all Helical Pile components, including corrosion protection and pile top attachment to the Owner for review and approval. This includes Helical Pile lead/starter and extension section identification (manufacturer's catalog numbers).
- E. If required, the Contractor shall submit certified mill test reports for the central steel shaft, as the material is delivered, to the Owner for record purposes. The ultimate strength, yield strength, % elongation, and chemistry composition shall be provided.
- F. The Contractor shall submit plans for pre-production (optional) and production testing for the Helical Piles to the Owner for review and acceptance prior to beginning load tests. The purpose of the test is to determine the load versus displacement response of the Helical Pile and provide an estimation of ultimate capacity.

- G. The Contractor shall submit to the Owner copies of calibration reports for each torque indicator or torque motor, and all load test equipment to be used on the project. The calibration tests shall have been performed within forty five (45) working days of the date submitted. Helical Pile installation and testing shall not proceed until the Owner has received the calibration reports. These calibration reports shall include, but are not limited to, the following information:
- a. Name of project and Contractor
 - b. Name of testing agency
 - c. Identification (serial number) of device calibrated
 - d. Description of calibrated testing equipment
 - e. Date of calibration
 - f. Calibration data
- H. Work shall not begin until all the submittals have been received and approved by the Owner. The Contractor shall allow the Owner a reasonable time to review, comment, and return the submittal package after a complete set has been received. All costs associated with incomplete or unacceptable submittals shall be the responsibility of the Contractor.

3.02 INSTALLATION RECORDS

- A. The Contractor shall provide the Owner copies of Helical Pile installation records within 24 hours after each installation is completed. Records shall be prepared in accordance with the specified division of responsibilities as noted in Table-1. Formal copies shall be submitted on a weekly basis. These installation records shall include, but are not limited to, the following information.
1. Name of project and Contractor
 2. Name of Contractor's supervisor during installation
 3. Date and time of installation
 4. Name and model of installation equipment
 5. Type of torque indicator used
 6. Location of Helical Pile by assigned identification number
 7. Actual Helical Pile type and configuration – including lead section (number and size of helix plates), number and type of extension sections (manufacturer's SKU numbers)
 8. Helical Pile installation duration and observations
 9. Total length of installed Helical Pile
 10. Cut-off elevation
 11. Inclination of Helical Pile
 12. Installation torque at one-foot intervals for the final 10 feet
 13. Comments pertaining to interruptions, obstructions, or other relevant information
 14. Rated load capacities

3.03 CLOSEOUT SUBMITTALS

- A. Warranty: Warranty documents specified herein

1. Project Warranty: Refer to Conditions of the Contract for project warranty provisions
 - a. Warranty Period: (*Specify Term*) years commencing on date of Substantial Completion
2. Manufacturer's Warranty: Submit, for Owner's Acceptance, manufacturer's standard warranty document executed by authorized company official. Manufacturer's warranty is in addition to, and not a limitation of, other rights the Owner may have under Contract Document.

PART 4 PRODUCTS AND MATERIALS

4.01 CENTRAL STEEL SHAFT:

- A. The central steel shaft, consisting of lead sections, helical extensions, and plain extensions, shall be Type SS (Square Shaft) or RS (Round Shaft) or a combination of the two (SS to RS Combo Pile) as manufactured by CHANCE Civil Construction (Centralia and Independence, MO) or equal.
 1. *SS5 1-1/2" Material:* Shall be hot rolled Round-Cornered-Square (RCS) solid steel bars meeting dimensional and workmanship requirements of ASTM A29. The bar shall be modified medium carbon steel grade (similar to AISI 1044) with improved strength due to fine grain size.
 - a. Torque strength rating = 5,500 ft-lb
 - b. Minimum yield strength = 70 ksi
 2. *SS125 1-1/4"; SS1375 1-3/8"; SS150 1-1/2"; SS175 1-3/4; SS200 2"; SS225 2-1/4" Material:* Shall be hot rolled Round-Cornered-Square (RCS) solid steel bars meeting the dimensional and workmanship requirements of ASTM A29. The bar shall be High Strength Low Alloy (HSLA), low to medium carbon steel grade with improved strength due to fine grain size.
 - a. Torque strength rating: SS125 = 4,000 ft-lb; SS1375 = 5,500 ft-lb; SS150 = 7,000 ft-lb; SS175 = 11,000 ft-lb; SS200 = 16,000 ft-lb; SS225 = 23,000 ft-lb
 - b. Minimum yield strength = 90 ksi
 3. *Type RS2875 2-7/8" OD Material:* Structural steel tube or pipe, welded or seamless, in compliance with ASTM A500 or A513. Wall thickness is 0.165", 0.203" or 0.262".
 - a. Torque strength rating: RS2875.165 = 4,500 ft-lb; RS2875.203 = 5,500 ft-lb; RS2875.262 = 7,500 ft-lb.
 - b. Minimum yield strength = 50 ksi
 4. *Type RS3500 3-1/2" OD Material:* Shall be structural steel tube or pipe, seamless or straight-seam welded, per ASTM A53, A252, ASTM A500, or ASTM A618. Wall thickness is 0.300" (schedule 80).
 - a. Torque strength rating = 13,000 ft-lb
 - b. Minimum yield strength = 50 ksi
 5. *Type RS4500 4-1/2" OD Material:* Shall be structural steel tube or pipe, seamless or straight-seam welded, per ASTM A500 or A513. Wall thickness is 0.337" (schedule 80).
 - a. Torque strength rating = 23,000 ft-lb

- b. Minimum yield strength = 50 ksi
- 6. *SS to RS2875 Combo Pile Material:* Shall be Type SS and RS2875 material as described above with a welded adapter for the transition from SS to RS2875.
- 7. *SS to RS3500 Combo Pile Material:* Shall be Type SS and RS3500 material as described above with a welded adapter for the transition from SS to RS3500.
- 8. *SS to RS4500 Combo Pile Material:* Shall be Type SS and RS4500 material as described above with a welded adapter for the transition from SS to RS4500.

4.02 HELIX BEARING PLATE:

- A. Shall be hot rolled carbon steel sheet, strip, or plate formed on matching metal dies to true helical shape and uniform pitch. Bearing plate material shall conform to the following ASTM specifications.
 - 1. *SS5 Material:* Per ASTM A572, or A1018, or A656 with minimum yield strength of 50 ksi. Plate thickness is 3/8".
 - 2. *SS125 and SS1375 Material:* Per ASTM A572 with minimum yield strength of 50 ksi. Plate thickness is 3/8" or 1/2".
 - 3. *SS150 and SS175 Material:* Per ASTM A656 or A1018 with minimum yield strength of 80 ksi. Plate thickness is 3/8" or 1/2".
 - 4. *SS200 and SS225 Material:* Per ASTM A656 or A1018 with minimum yield strength of 80 ksi. Plate thickness is 1/2".
 - 5. *RS2875 Material:* Per ASTM A36, or A572, with minimum yield strength of 36 ksi. Plate thickness is 3/8" or 1/2".
 - 6. *RS3500 Material:* Per ASTM A36, or A572, or A1018, or A656 depending on helix diameter, per the minimum yield strength requirements cited above. Plate thickness is 3/8" or 1/2".
 - 7. *RS4500 Material:* Per ASTM A572 with minimum yield strength of 50 ksi. Plate thickness is 1/2".

4.03 BOLTS:

- A. The size and type of bolts used to connect the central steel shaft sections together shall conform to the following ASTM specifications.
 - 1. *SS125 1-1/4" Material:* 5/8" diameter bolt (2 per coupling) per SAE J429 Grade 8.
 - 2. *SS1375 1-3/8" Material:* 3/4" diameter bolt (2 per coupling) per SAE J429 Grade 8.
 - 3. *SS5 and SS150 1-1/2" Material:* 3/4" diameter bolt per ASTM A320 Grade L7 or ASTM A325.
 - 4. *SS175 1-3/4" Material:* 7/8" diameter bolt per ASTM A193 Grade B7.
 - 5. *SS200 2" Material:* 1-1/8" diameter bolt per ASTM A193 Grade B7.
 - 6. *SS225 2-1/4" Material:* 1-1/4" diameter bolt per ASTM A193 Grade B7.
 - 7. *RS2875 2-7/8" OD Material:* 3/4" diameter bolts (2 or 4 per coupling) per SAE J429 Grade 5 or 8.
 - 8. *RS3500 3-1/2" OD Material:* 3/4" diameter bolts (3 or 4 per coupling) per SAE J429 Grade 5 or 8.

9. *RS4500 4-1/2" OD Material: 3/4" diameter bolts (4 per coupling) per SAE J429 Grade 8.*

4.04 COUPLINGS

- A. For type SS5, SS150, SS175, SS200, and SS225 material, the coupling shall be formed as an integral part of the plain and helical extension material as hot upset forged sockets. For Type SS125 and SS1375 material, the coupling shall be a cast steel sleeve with two holes for connecting shaft sections together.
- B. For Type RS2875, RS3500, and RS4500 material, the couplings shall either be formed as an integral part of the plain and helical extension material as hot forge expanded sockets, or as internal sleeve wrought steel connectors. The steel connectors can be either tubing or solid steel bar with holes for connecting shaft sections together.

4.05 PLATES, SHAPES, OR PILE CAPS:

- A. Depending on the application, the pile cap shall be a welded assembly consisting of structural steel plates and shapes designed to fit the pile and transfer the applied load. Structural steel plates and shapes for HELICAL PILE top attachments shall conform to ASTM A36 or ASTM A572 Grade 50.

4.06 CORROSION PROTECTION (OPTIONAL):

- A. Epoxy Coating: If used, the thickness of coating applied electrostatically to the central steel shaft shall be 7-12 mils. Epoxy coating shall be in accordance with ASTM A775. Bend test requirements are not required. Coupling bolts and nuts are not required to be epoxy coated.
- B. Galvanization: If used, all Hubbell Power Systems, Inc./A. B. Chance Type SS material or equal shall be hot-dipped galvanized in accordance with ASTM A153 after fabrication. All Hubbell Power Systems, Inc./A. B. Chance Type RS material or equal shall be hot-dipped galvanized in accordance with ASTM A153 or A123 as specified after fabrication.

PART 5 EXECUTION

5.01 SITE CONDITIONS

- A. Prior to commencing Helical Pile installation, the Contractor shall inspect the work of all other trades and verify that all said work is completed to the point where Helical Piles may commence without restriction.
- B. The Contractor shall verify that all Helical Piles may be installed in accordance with all pertinent codes and regulations regarding such items as underground obstructions, right-of-way limitations, utilities, etc.
- C. In the event of a discrepancy, the Contractor shall notify the Owner. The Contractor shall not proceed with Helical Pile installation in areas of discrepancies until said discrepancies have been resolved. All costs associated with unresolved discrepancies shall be the responsibility of the Owner.

5.02 INSTALLATION EQUIPMENT

- A. Shall be rotary type, hydraulic power driven torque motor with clockwise and counter-clockwise rotation capabilities. The torque motor shall be capable of continuous adjustment to revolutions per minute (RPM's) during installation. Percussion drilling equipment shall not be permitted. The torque motor shall have torque capacity 15% greater than the torsional strength rating of the central steel shaft to be installed.

- B. Equipment shall be capable of applying adequate down pressure (crowd) and torque simultaneously to suit project soil conditions and load requirements. The equipment shall be capable of continuous position adjustment to maintain proper Helical Pile alignment.

5.03 INSTALLTION TOOLING

- A. Shall consist of a Kelly Bar Adapter (KBA) and Type SS or RS drive tools as manufactured by CHANCE Civil Construction or equal and used in accordance with the manufacturers written installation instructions.
- B. A torque indicator shall be used during Helical Pile installation. The torque indicator can be an integral part of the installation equipment or externally mounted in-line with the installation tooling.
 - 1. Shall be capable of providing continuous measurement of applied torque throughout the installation.
 - 2. Shall be capable of torque measurements in increments of at least 500 ft-lb
 - 3. Shall be calibrated prior to pre-production testing or start of work. Torque indicators which are an integral part of the installation equipment, shall be calibrated on-site. Torque indicators which are mounted in-line with the installation tooling, shall be calibrated either on-site or at an appropriately equipped test facility. Indicators that measure torque as a function of hydraulic pressure shall be calibrated at normal operating temperatures.
 - 4. Shall be re-calibrated, if in the opinion of the Owner and/or Contractor reasonable doubt exists as to the accuracy of the torque measurements.

5.04 INSTALLATION PROCEDURES

- A. Central Steel Shaft: (Lead and Extension Sections)
 - 1. The Helical Pile installation technique shall be such that it is consistent with the geotechnical, logistical, environmental, and load carrying conditions of the project.
 - 2. The lead section shall be positioned at the location as shown on the working drawings. Battered Helical Piles can be positioned perpendicular to the ground to assist in initial advancement into the soil before the required batter angle shall be established. The Helical Pile sections shall be engaged and advanced into the soil in a smooth, continuous manner at a rate of rotation of 5 to 20 RPM's. Extension sections shall be provided to obtain the required minimum overall length and installation torque as shown on the working drawings. Connect sections together using coupling bolt(s) and nut torqued to 40 ft-lb.
 - 3. Sufficient down pressure shall be applied to uniformly advance the Helical Pile sections approximately 3 inches per revolution. The rate of rotation and magnitude of down pressure shall be adjusted for different soil conditions and depths.

5.05 TERMINATION CRITERIA

- A. The torque as measured during the installation shall not exceed the torsional strength rating of the central steel shaft.
- B. The minimum installation torque and minimum overall length criteria as shown on the working drawings shall be satisfied prior to terminating the Helical Pile installation.
- C. If the torsional strength rating of the central steel shaft and/or installation equipment has been reached prior to achieving the minimum overall length required, the Contractor shall have the following options:

Humboldt Bay Municipal Water District
Samoa Reservoir Seismic Retrofit

1. Terminate the installation at the depth obtained subject to the review and acceptance of the Owner, or:
 2. Remove the existing Helical Pile and install a new one with fewer and/or smaller diameter helix plates. The new helix configuration shall be subject to review and acceptance of the Owner. If re-installing in the same location, the top-most helix of the new Helical Pile shall be terminated at least (3) three feet beyond the terminating depth of the original Helical Pile.
- D. If the minimum installation torque as shown on the working drawings is not achieved at the minimum overall length, and there is no maximum length constraint, the Contractor shall have the following option:
1. Remove the existing Helical Pile and install a new one with additional and/or larger diameter helix plates. The new helix configuration shall be subject to review and acceptance of the Owner. The top-most helix of the new Helical Pile shall be terminated at least (3) three feet beyond the terminating depth of the original Helical Pile.
- E. If the Helical Pile is refused or deflected by a subsurface obstruction, the installation shall be terminated and the pile removed. The obstruction shall be removed, if feasible, and the Helical Pile re-installed. If the obstruction can't be removed, the Helical Pile shall be installed at an adjacent location, subject to review and acceptance of the Owner.
- F. If the torsional strength rating of the central steel shaft and/or installation equipment has been reached prior to proper positioning of the last plain extension section relative to the final elevation, the Contractor may remove the last plain extension and replace it with a shorter length extension. If it is not feasible to remove the last plain extension, the Contractor may cut said extension shaft to the correct elevation. The Contractor shall not reverse (back-out) the Helical Pile to facilitate extension removal.
- G. The average torque for the last three feet of penetration shall be used as the basis of comparison with the minimum installation torque as shown on the working drawings. The average torque shall be defined as the average of the last three readings recorded at one-foot intervals.

END OF SECTION

STRUCTURAL CALCULATIONS Samoa Reservoir Seismic Retrofit Project

For



HUMBOLDT BAY MUNICIPAL WATER DISTRICT
828 7th Street, Eureka, CA 95501

APRIL 2024



Prepared by



2235 Mercury Way
Suite 150,
Santa Rosa, CA 95407
(707) 523-1010

Table of Contents

Design Criteria	1
1 MG Samoa Tank	
Existing Tank Evaluation.....	2
Retrofit Tank Calculations.....	7
Helical Screw Anchor Design Loads.....	12
Anchor Chair Design	19
Concrete Pile Cap Design	
CIDH Pile Section Design	20
Pile Cap Beam Design	31
CIDH Pile Length	34
Headed Stud Design.....	36

Design Criteria

AWWA D100-11

ACI 318-14

Project: **HBMWD Reservoirs Seismic Retrofit Project (3 tanks)**
 Client: **Humboldt Bay Municipal Water District**
 Project #: **12627733**
 Tank: **1MG Samoa**

Welded Steel Water Storage Tank
 Design Calculations per AWWA D100-11

EVALUATION CALCULATIONS

The following calculations reference the design and procedures outlined in AWWA D100-11

STEEL TANK INPUT PARAMETERS - GROUND SUPPORTED

Geometry and Construction		1967	Year Designed
D = 70.0 ft	Tank Diameter	E = 0.85	Joint Efficiency
R = 35.0 ft	Tank Radius	DMT >= 20 ° F	Design Metal Temp [Ch 14]
Ht = 40.0 ft	Tank Shell Height	G = 1.00	Specific Gravity
H = 37.0 ft	Liquid Height, MOL	TCL = 37.0 ft	Top Capacity Level, overflow
Op Cap = 1.1 MG	Nominal storage capacity	γ_L = 62.4 pcf	Unit Weight
Max Cap = 1.1 MG	Nominal storage capacity	FB = 3.0 ft	Available Freeboard
W_T = 8,885 kips	Weight of liquid ("contents"); Operating level		

Seismic			
Lat = 40.805 °	Latitude (for USGS Design Map)		
Long = -124.199 °	Longitude (for USGS Design Map)		
Site = D	Site Class, ASCE 7-16, Ch 20		
S_1 = 1.09 g	Mapped MCE_R Spect Response, 1-sec, ASCE 7-16 / USGS		
S_{DS} = 1.20 g	Spectral Accel, Short, ASCE 7-16 (5% damped) / USGS		
S_{D1} = 1.87 g	Spectral Accel, 1-sec, ASCE 7-16 (5% damped) / USGS	(used 7-10)	
T_L = 8.0 s	Long period transition period, ASCE 7-16 / USGS		
Group = III	Seismic Use Group		
I_E = 1.50	Seismic Use Factor	[Table 21]	
Anchor = SELF	Self-Anchoring or Mechanical		

Wind			
V_{3s} = 85 mph	Wind Velocity, 3-second gust [ASCE 7-10]	G = 1.00	Gust Factor
Angle	Roof Type		
C_f = 0.60	Wind Drag Factor, lateral	[Table 2]	
C_{fR} = -0.5	Wind Drag Factor, uplift ("suction") at roof, average		
K_z = 1.09	Velocity pressure coeff	[Table 3]	
P_w = 18.0 psf	Wind lateral pressure, ASD level ($I=1.15$)	[Eq 3-1]	
P_w = -12.3 psf	Wind roof pressure, ASD level ($I=1.15$)		

SUMMARY OF STEEL PLATE WEIGHTS

t_r = 0.250 in	Roof PL thick	W_{rp} = 39,286 lbs	Roof plate (nearly flat)
t_k = 0.250 in	Knuckle PL thick	W_{rk} = 0 lbs	Knuckle plate (6" radius)
p_r = 5.0 psf	Roof framing self wt (est)	W_{rf} = 19,242 lbs	Roof framing (estimate)
t_f = 0.250 in	Floor PL thick	W_r = 58,529 lbs	Total roof steel wt
		W_f = 39,286	Floor steel wt

Shell (Wall) Weights

Ring No.	Ring Ht (ft)	Shell PL t_{USED} (in)	Weight per Ring (kips)	X_i (ft)	Ring Ht * X_i (ft ²)	$W_i * X_i$ (kips-ft)	(Ring Ht) * (t_i) * (X_i) (ft)
5	8.0	0.292	21.0	36	3,456	755	1,009
4	8.0	0.278	20.0	28	2,688	559	747
3	8.0	0.318	22.8	20	1,920	457	611
2	8.0	0.426	30.6	12	1,152	367	491
Base	8.0	0.495	35.6	4	384	142	190
	40.0	W_s =	130.0		9,600	2,281	3,048

X_s = 17.6 ft Effective average height of shell
 t_u = 0.317 in Effective average thickness of shell

HYDROSTATIC DESIGN

Ring No.	Ring Ht (ft)	Steel Material	Max unit tension [Table 34] (psi)	Design Fluid Depth (ft)	Design Pt Elev (ft)	Hoop Force at Design Pt (lbs/in)	Shell PL $t_{REQ'D}$ (in)	Shell PL t_{USED} (in)	Shell PL Code t_{MIN} (in)	Shell PL Hoop Stress (psi)	Allow Hoop Stress (psi)
-	(ft)	-	(psi)	(ft)	(ft)	(lbs/in)	(in)	(in)	(in)	(psi)	(psi)
5	8.0	A36	19,330	5.0	32.0	910	0.047	0.292	0.250	3116	16431
4	8.0	A36	19,330	13.0	24.0	2,366	0.122	0.278	0.250	8511	16431
3	8.0	A36	19,330	21.0	16.0	3,822	0.198	0.318	0.250	12019	16431
2	8.0	A36	19,330	29.0	8.0	5,278	0.273	0.426	0.250	12390	16431
Base	8.0	A36	19,330	37.0	0.0	6,734	0.348	0.495	0.250	13604	16431
40.0											83%

Assume steel material is A36

Notes:

Unit Hydrostatic Hoop Force = $2.6 \times D \times G / E =$ 214.1 lbs / in of shell height / foot of water depth
 Hoop Force at Design Point = $2.6 \times H_p \times D \times G / E$
 Shell Plate Thickness, $t = 2.6 \times H_p \times D \times G / s \times E$ [Eq. 3-40]

SEISMIC ACTIONS

D/H =	1.89	Aspect ratio, Diameter to MOL	
I _E =	1.50	Importance factor	
S ₁ =	1.09 g	Mapped MCE _R Spect Response, 1-sec	
S _{DS} =	1.20 g	Spectral Accel, Short, ASCE 7-10 (5% damped)	
S _{D1} =	1.87 g	Spectral Accel, 1-sec, ASCE 7-10 (5% damped)	
T _i =	0.00 s	Natural period of structure (assumed to be zero per Section 13.5)	
T _s =	1.56 s	Transition period	$T_s = S_{D1}/S_{DS}$
T _c =	4.83 s	Convective period	[Eq 13-22]
T _L =	8.00 s	Long period transition period	
S _{ai} =	1.20 g	Design spectral accel, Impulsive, 5% damping (assumes Ti=0)	[Eq 13-9]
S _{ac} =	0.581 g	Design spectral accel, Convective, 0.5% damping	[Eq 13-12, 13-13]
R _i =	2.5	Response Mod Factor, Impl (Anchor dependent)	[Table 28]
R _c =	1.5	Response Mod Factor, Conv	[Table 28]
A _{iMIN} =	0.24 g	Impulsive design accel, minimum	[Eq 13-17]
A _i =	0.51 g	Impulsive design accel	[Eq 13-17]
A _c =	0.41 g	Convective design accel	[Eq 13-18]
A _v =	0.17 g	Vertical ground motion	[Section 13.5.4.3]
A _f =	0.58 g	Convective design accel for sloshing	[Eq 13-53 to 56]
d =	20.3 ft	Slosh wave height above MOL	[Eq 13-52]

FB_{Req'd} = 20.3 ft Required freeboard [Table 29]
Insufficient Freeboard

SEISMIC ACTIONS Cont'd

Effective Seismic Weights and Heights

$W_T =$	8,885 kips	Weight of liquid ("contents")	
$W_i / W_T =$	0.57	Effective Impulsive ratio (force from "lower" constrained fluid)	[Eq 13-24, 25]
$W_i =$	5,029 kips	Effective Impulsive weight	[Eq 13-24, 25]
$X_i =$	13.9 ft	Effective Impulsive height resultant above tank base, EBP	[Eq 13-28, 29]
$W_c / W_T =$	0.42	Effective Convective ratio (force from "upper" sloshing fluid)	[Eq 13-26]
$W_c =$	3,710 kips	Effective Convective weight	[Eq 13-26]
$X_c =$	22.7 ft	Effective Convective height resultant above tank base, EBP	[Eq 13-30]

Seismic Demand

$W_s =$	130.0 kips	Tank shell weight	
$X_s =$	17.6 ft	Tank shell centroid	
$W_r =$	58.5 kips	Tank roof weight	
$H_t =$	40.0 ft	Tank roof height	
$W_f =$	39.3 kips	Tank bottom (floor) weight	
$V_f =$	3,111 kips	Design shear at top of fdn	[Eq 13-31]
$M_s =$	51,834 kip-ft	Design OTM at bottom of shell (EBP)	[Eq 13-23]
$b =$	35 ft	Tributary roof plate length along tank perimeter - <i>assume equal to tank radius</i>	
$w_{rs} =$	266 plf	Weight of roof perimeter resisting OTM ($W_r/\pi D$ for tank without central column)	
$w_t =$	857 plf	Weight of tank shell and tributary roof load at perimeter	[Eq 13-41]
$w_t' =$	799 plf	Effective weight at perimeter $w_t' = w_t(1-0.4*Av)$	
$t_b =$	0.25 in	Design thickness, bottom annulus floor ring (governing thickness)	
$F_y =$	36,000 psi	Yield strength, bottom annulus	
$W_{Lmax} =$	3315 plf	Limit, Weight of fluid resisting OTM, $w_{Lmax} = 1.28HDG$	[Eq 13-37]
$w_L =$	2279 plf	Weight of fluid resisting OTM	[Eq 13-37]
$J =$	3.44	Overtopping ratio	[Eq 13-36]
$L_{MAX} =$	2.5 ft	Limit, Req'd width of bottom annulus	
$L =$	1.7 ft	Req'd bottom annulus	[Eq 13-38]

Mechanical Anchoring Required

Sliding Check

$\mu =$	0.58	Lower bound, Coefficient of sliding friction	
$\mu =$	0.58	Coefficient of sliding friction	
$V_{ALLOW} =$	4,808 kips	Sliding resistance (capacity) to seismic shear	[Eq 13-57]

D/C = **0.65** Demand vs Capacity, seismic sliding
 Sliding OK

SEISMIC STRESSES

Tank Seismic Stresses - Compressive

Anchor = SELF	Self-Anchoring or Mechanical	
$w_1'' = 915$ plf	Effective shell unit weight	$w_1'' = w_1''(1+0.4*Av)$
$\sigma_{c1} = 2421$ psi	Demand, Long't compr stress (For $J < 0.785$, or Mech Anchor)	[Eq 13-39]
$\sigma_{c2} = -592$ psi	Demand, Long't compr stress (For $0.785 < J < 1.54$)	[Eq 13-40]
$\sigma_c = N/A$ psi	Governing Demand, Long't compr stress	
$R = 420$ in	Tank radius	
$t_b/R = 0.0012$	Ratio, shell thickness to tank radius, lowest shell	$(t/R)_c = 0.003537$ (Class 2 mat)
$1/R_{Min} = 0.0010$	Limit, lower bound t/R per Method 2 (Reference Only)	
$p = 16.0$ psi	Hydrostatic pressure	
$K_0 = 1.25$	Buckling coefficient, upper limit = 1.25	[Eq 3-17]
$FL_1 = 2,206$ psi	Allowable local elastic buckling, Method 1 (static)	[Eq 3-11, Table 11]
$FL_2 = 2,757$ psi	Allowable local elastic buckling, Method 2 (Reference Only)	[Eq 3-14]
$(P/E)(R/t)^2 = 0.40$	[Assumed > 0.064]	[Eq 13-50, 13-51]
$\Delta C_c = 0.15$	Pressure-stabilizing buckling coefficient, Limit = 0.22	[Eq 13-51]
$\Delta \sigma_{cr} = 5,221$ psi	Critical buckling increase for self anchored tank due to p	[Eq 13-49]
$\sigma_e = 6,405$ psi	Seismic allowable compr stress, including 1.33 increase	[Eq 13-47]
$D/C = N/A$	Compressive stress demand vs capacity at bottom shell	

Compressive stresses cannot be calculated - Anchoring Req'd

Tank Seismic Stresses - Tension

$D/H = 1.89$

Ring No.	Y, Design Fluid Depth (ft)	Design Pt Elev (ft)	[Eq 13-39 to 41] N_i (lbs/in)	[Eq 13-42] N_c (lbs/in)	$N_h * A_v$ (lbs/in)	Hydrostatic hoop N_h (lbs/in)	Shell PL t_{USED} (in)	Seismic hoop σ_s (psi)	Static hoop σ_{static} (psi)	Total hoop $\sigma_{static} + \sigma_s$ (psi)	D/C	
-	(ft)	(ft)	(lbs/in)	(lbs/in)	(lbs/in)	(lbs/in)	(in)	(psi)	(psi)	(psi)	-	
5	5	32	700	1553	153	910	0.292	5858	3116	8,974	0.41	OK
4	13	24	1610	1065	397	2,366	0.278	7088	8511	15,599	0.71	OK
3	21	16	2259	768	642	3,822	0.318	7771	12019	19,789	0.90	OK
2	29	8	2649	608	887	5,278	0.426	6711	12390	19,101	0.87	OK
Base	37	0	2779	558	1131	6,734	0.495	6165	13604	19,769	0.90	OK

Required Anchoring

$J = 3.44$	Overturning ratio	[Eq 13-36]
Anchor = SELF	Self-Anchoring or Mechanical	
$N = 44$	Number of Tension Anchors around tank perimeter	
$D_{ac} = 72.0$ ft	Diameter of anchor circle = $D+2x(1.0')$, anchors are spaced 1.0-ft off of tank shell	
$s = 5.1$ ft	Anchor spacing	
$M_s = 51,834$ kip-ft	Seismic overturning	[Eq 13-23]
$W' = 188$ kips	$W' = w_1'' * D * \pi$	
$P_s = N/A$ kips per anchor		[Eq 3-42]

Net Tension

1.638 0.927192

WIND DESIGN - TANK EMPTY

Wind

$V_{3s} =$	85 mph	Wind Velocity, 3-second gust [Provided]	
	Angle	Roof Type	
$C_f =$	0.60	Wind Drag Factor, lateral	Table 2
$C_{fR} =$	-0.53	Wind Drag Factor, uplift ("suction") at roof, average	
$K_z =$	1.09	Velocity pressure coeff	Table 3
$P_w =$	18.0 psf	Wind lateral pressure, ASD level	[Eq 3-1]
$P_{wR} =$	-12.3 psf	Wind roof pressure, ASD level	

Local shell plate bending / Stiffener check

$t' =$	0.275 in	Min req'd average shell PL thickness for wind [Eq 3-36]
		Avg Shell Thickness, $t' = (P_w \times D^{3/2} \times H_s / 10.625 \times 10^6) ^{2/5}$
$t_{ave} =$	0.362 in	OK

Stability check - Sliding - Wind

$\mu =$	0.58	Lower bound, Coefficient of sliding friction	
$\mu =$	0.80	Coefficient of sliding friction for wind	
$F_{up} =$	-47 kips	Net uplift concurrent with lateral load (no reduction)	
$W_{stl} =$	228 kips	Total steel weight (Roof, shells, floor PL)	
$V_{ALLOW_W} =$	75.4 kips	Sliding resistance (capacity) to wind	$V_{ALLOW_W} = \mu \cdot (0.6 \cdot W_{stl} + 0.9 \cdot F_{up})$
$V_{Wind} =$	45.4 kips	Driving sliding demand, $V = 0.9 \cdot P_w \cdot A_{SIDE}$	$V_{WIND} = 0.9 \cdot P_w \cdot A_{SIDE}$
$D/C =$	0.60		

Wind Sliding OK

Stability check - Overturning - Wind

$M_{ALLOW_W} =$	3,298 kip-ft	OTM resistance (capacity) to wind	$M_{ALLOW_W} = (0.6 \cdot W_{stl} + 0.9 \cdot F_{up}) \cdot D/2$
$M_{Wind} =$	907 kip-ft	Driving OTM demand, $M_{WIND} = V_{WIND} \cdot Ht/2$	
$D/C =$	0.28		

Wind Overturning OK

Basis for design for Stability:

ASCE 7-10, Eq 2.4.1, Eq 7, with Except 2 and $0.6W = W$
 with Exception 2 and $0.6W = W$

Project: **HBMWD Reservoirs Seismic Retrofit Project (3 tanks)**
 Client: **Humboldt Bay Municipal Water District**
 Project #: **12627733**
 Tank: **1MG Samoa**

Welded Steel Water Storage Tank
 Design Calculations per AWWA D100-11

RETROFIT CALCULATIONS

The following calculations reference the design and procedures outlined in AWWA D100-11

STEEL TANK INPUT PARAMETERS - GROUND SUPPORTED

Geometry and Construction

D = 70.0 ft	Tank Diameter	E = 0.85	Year Designed
R = 35.0 ft	Tank Radius	DMT >= 20 ° F	Joint Efficiency
Ht = 40.0 ft	Tank Shell Height	G = 1.00	Design Metal Temp [Ch 14]
H = 37.0 ft	Liquid Height, MOL	TCL = 37.0 ft	Specific Gravity
Op Cap = 1.1 MG	Nominal storage capacity	γ_L = 62.4 pcf	Top Capacity Level, overflow
Max Cap = 1.1 MG	Nominal storage capacity	FB = 3.0 ft	Unit Weight
W_T = 8,885 kips	Weight of liquid ("contents"); Operating level		Available Freeboard

Seismic

Lat = 40.805 °	Latitude (for USGS Design Map)	
Long = -124.199 °	Longitude (for USGS Design Map)	
Site = D	Site Class, ASCE 7-16, Ch 20	
S_1 = 1.09 g	Mapped MCE_R Spect Response, 1-sec, ASCE 7-16 / USGS	
S_{DS} = 1.20 g	Spectral Accel, Short, ASCE 7-16 (5% damped) / USGS	
S_{D1} = 1.87 g	Spectral Accel, 1-sec, ASCE 7-16 (5% damped) / USGS	(used 7-10)
T_L = 8.0 s	Long period transition period, ASCE 7-16 / USGS	
Group = III	Seismic Use Group	
I_E = 1.50	Seismic Use Factor	[Table 21]
Anchor = MECH	Self-Anchoring or Mechanical	

Wind

V_{3s} = 85 mph	Wind Velocity, 3-second gust [ASCE 7-10]	G = 1.00	Gust Factor
Angle	Roof Type		
C_f = 0.60	Wind Drag Factor, lateral		[Table 2]
C_{fR} = -0.5	Wind Drag Factor, uplift ("suction") at roof, average		
K_z = 1.09	Velocity pressure coeff		[Table 3]
P_w = 18.0 psf	Wind lateral pressure, ASD level (I=1.15)		[Eq 3-1]
P_w = -12.3 psf	Wind roof pressure, ASD level (I=1.15)		

SUMMARY OF STEEL PLATE WEIGHTS

t_r = 0.250 in	Roof PL thick	W_{rp} = 39,286 lbs	Roof plate (nearly flat)
t_k = 0.250 in	Knuckle PL thick	W_{rk} = 0 lbs	Knuckle plate (6" radius)
p_r = 5.0 psf	Roof framing self wt (est)	W_{rf} = 19,242 lbs	Roof framing (estimate)
t_f = 0.250 in	Floor PL thick	W_r = 58,529 lbs	Total roof steel wt
		W_f = 39,286	Floor steel wt

Shell (Wall) Weights

Ring No.	Ring Ht (ft)	Shell PL t_{USED} (in)	Weight per Ring (kips)	X_i (ft)	Ring Ht * X_i (ft ²)	$W_i * X_i$ (kips-ft)	(Ring Ht) * (t_i) * (X_i) (ft)
-	(ft)	(in)	(kips)	(ft)	(ft ²)	(kips-ft)	(ft)
5	8.0	0.292	21.0	36	3,456	755	1,009
4	8.0	0.278	20.0	28	2,688	559	747
3	8.0	0.318	22.8	20	1,920	457	611
2	8.0	0.426	30.6	12	1,152	367	491
Base	8.0	0.495	35.6	4	384	142	190
	40.0	W_s =	130.0		9,600	2,281	3,048

X_s = 17.6 ft Effective average height of shell
 t_u = 0.317 in Effective average thickness of shell

HYDROSTATIC DESIGN

Ring No.	Ring Ht	Steel Material	Max unit tension [Table 34]	Design Fluid Depth	Design Pt Elev	Hoop Force at Design Pt	Shell PL $t_{REQ'D}$	Shell PL t_{USED}	Shell PL Code t_{MIN}	Shell PL Hoop Stress	Allow Hoop Stress
-	(ft)	-	(psi)	(ft)	(ft)	(lbs/in)	(in)	(in)	(in)	(psi)	(psi)
5	8.0	A36	19,330	5.0	32.0	910	0.047	0.292	0.250	3116	16431
4	8.0	A36	19,330	13.0	24.0	2,366	0.122	0.278	0.250	8511	16431
3	8.0	A36	19,330	21.0	16.0	3,822	0.198	0.318	0.250	12019	16431
2	8.0	A36	19,330	29.0	8.0	5,278	0.273	0.426	0.250	12390	16431
Base	8.0	A36	19,330	37.0	0.0	6,734	0.348	0.495	0.250	13604	16431

40.0

Assume steel material is A36

83%

Notes:

Unit Hydrostatic Hoop Force = $2.6 \times D \times G / E =$ lbs / in of shell height / foot of water depth
 Hoop Force at Design Point = $2.6 \times H_p \times D \times G / E$
 Shell Plate Thickness, $t = 2.6 \times H_p \times D \times G / s \times E$ [Eq. 3-40]

SEISMIC ACTIONS

D/H = <input type="text" value="1.89"/>	Aspect ratio, Diameter to MOL	
$I_E =$ <input type="text" value="1.50"/>	Importance factor	
$S_1 =$ <input type="text" value="1.09 g"/>	Mapped MCE_R Spect Response, 1-sec	
$S_{DS} =$ <input type="text" value="1.20 g"/>	Spectral Accel, Short, ASCE 7-10 (5% damped)	
$S_{D1} =$ <input type="text" value="1.87 g"/>	Spectral Accel, 1-sec, ASCE 7-10 (5% damped)	
$T_i =$ <input type="text" value="0.00 s"/>	Natural period of structure (assumed to be zero per Section 13.5)	
$T_s =$ <input type="text" value="1.56 s"/>	Transition period	$T_s = S_{D1}/S_{DS}$
$T_c =$ <input type="text" value="4.83 s"/>	Convective period	[Eq 13-22]
$T_L =$ <input type="text" value="8.00 s"/>	Long period transition period	
$S_{ai} =$ <input type="text" value="1.20 g"/>	Design spectral accel, Impulsive, 5% damping (assumes $T_i=0$)	[Eq 13-9]
$S_{ac} =$ <input type="text" value="0.581 g"/>	Design spectral accel, Convective, 0.5% damping	[Eq 13-12, 13-13]
$R_i =$ <input type="text" value="3.0"/>	Response Mod Factor, Impl (Anchor dependent)	[Table 28]
$R_c =$ <input type="text" value="1.5"/>	Response Mod Factor, Conv	[Table 28]
$A_{iMIN} =$ <input type="text" value="0.20 g"/>	Impulsive design accel, minimum	[Eq 13-17]
$A_i =$ <input type="text" value="0.43 g"/>	Impulsive design accel	[Eq 13-17]
$A_c =$ <input type="text" value="0.41 g"/>	Convective design accel	[Eq 13-18]
$A_v =$ <input type="text" value="0.17 g"/>	Vertical ground motion	[Section 13.5.4.3]
$A_f =$ <input type="text" value="0.58 g"/>	Convective design accel for sloshing	[Eq 13-53 to 56]
$d =$ <input type="text" value="20.3 ft"/>	Slosh wave height above MOL	[Eq 13-52]

$FB_{Req'd} =$ Required freeboard [Table 29]

Insufficient Freeboard

SEISMIC ACTIONS Cont'd

Effective Seismic Weights and Heights

$W_T =$	8,885 kips	Weight of liquid ("contents")	
$W_i / W_T =$	0.57	Effective Impulsive ratio (force from "lower" constrained fluid)	[Eq 13-24, 25]
$W_i =$	5,029 kips	Effective Impulsive weight	[Eq 13-24, 25]
$X_i =$	13.9 ft	Effective Impulsive height resultant above tank base, EBP	[Eq 13-28, 29]
$W_c / W_T =$	0.42	Effective Convective ratio (force from "upper" sloshing fluid)	[Eq 13-26]
$W_c =$	3,710 kips	Effective Convective weight	[Eq 13-26]
$X_c =$	22.7 ft	Effective Convective height resultant above tank base, EBP	[Eq 13-30]

Seismic Demand

$W_s =$	130.0 kips	Tank shell weight	
$X_s =$	17.6 ft	Tank shell centroid	
$W_r =$	58.5 kips	Tank roof weight	
$H_t =$	40.0 ft	Tank roof height	
$W_f =$	39.3 kips	Tank bottom (floor) weight	
$V_f =$	2,728 kips	Design shear at top of fdn	[Eq 13-31]
$M_s =$	47,323 kip-ft	Design OTM at bottom of shell (EBP)	[Eq 13-23]
$b =$	35 ft	Tributary roof plate length along tank perimeter - <i>assume equal to tank radius</i>	
$w_{rs} =$	266 plf	Weight of roof perimeter resisting OTM ($W_r/\pi D$ for tank without central column)	
$w_t =$	857 plf	Weight of tank shell and tributary roof load at perimeter	[Eq 13-41]
$w_t' =$	799 plf	Effective weight at perimeter $w_t' = w_t(1-0.4*Av)$	
$t_b =$	0.25 in	Design thickness, bottom annulus floor ring (governing thickness)	
$F_y =$	36,000 psi	Yield strength, bottom annulus	
$W_{L,max} =$	3315 plf	Limit, Weight of fluid resisting OTM, $w_{L,max} = 1.28HDG$	[Eq 13-37]
$w_L =$	2279 plf	Weight of fluid resisting OTM	[Eq 13-37]
$J =$	3.14	Overturning ratio	[Eq 13-36]
$L_{MAX} =$	2.5 ft	Limit, Req'd width of bottom annulus	
$L =$	1.7 ft	Req'd bottom annulus	[Eq 13-38]

OK

Sliding Check

$\mu =$	0.58	Lower bound, Coefficient of sliding friction	
$\mu =$	0.58	Coefficient of sliding friction	
$V_{ALLOW} =$	4,808 kips	Sliding resistance (capacity) to seismic shear	[Eq 13-57]

D/C = 0.57 Demand vs Capacity, seismic sliding
 Sliding OK

SEISMIC STRESSES

Tank Seismic Stresses - Compressive

Anchor =	MECH	Self-Anchoring or Mechanical	
w_t'' =	915 plf	Effective shell unit weight	$w_t'' = w_t'(1+0.4*Av)$
σ_{c1} =	2224 psi	Demand, Long't compr stress (For $J < 0.785$, or Mech Anchor)	[Eq 13-39]
σ_{c2} =	-655 psi	Demand, Long't compr stress (For $0.785 < J < 1.54$)	[Eq 13-40]
σ_c =	2224 psi	Governing Demand, Long't compr stress	
R =	420 in	Tank radius	
t_b/R =	0.0012	Ratio, shell thickness to tank radius, lowest shell	$(t/R)_c = 0.003537$ (Class 2 mat)
t/R_{Min} =	0.0010	Limit, lower bound t/R per Method 2 (Reference Only)	
p =	16.0 psi	Hydrostatic pressure	
K_o =	1.25	Buckling coefficient, upper limit = 1.25	[Eq 3-17]
FL_1 =	2,206 psi	Allowable local elastic buckling, Method 1 (static)	[Eq 3-11, Table 11]
FL_2 =	2,757 psi	Allowable local elastic buckling, Method 2 (Reference Only)	[Eq 3-14]
$(P/E)(R/t)^2$ =	0.40	[Assumed > 0.064]	[Eq 13-50, 13-51]
ΔC_c =	0.15	Pressure-stabilizing buckling coefficient, Limit = 0.22	[Eq 13-51]
$\Delta \sigma_{cr}$ =	0 psi	Critical buckling increase for self anchored tank due to p	[Eq 13-49]
σ_e =	2,934 psi	Seismic allowable compr stress, including 1.33 increase	[Eq 13-47]
D/C =	0.76	Compressive stress demand vs capacity at bottom shell	

Tank Seismic Stresses - Tension

D/H = 1.89

Ring No.	Y, Design Fluid Depth (ft)	Design Pt Elev (ft)	[Eq 13-39 to 41] N_i (lbs/in)	[Eq 13-42] N_c (lbs/in)	N_h*Av (lbs/in)	Hydro-static hoop N_h (lbs/in)	Shell PL t_{USED} (in)	Seismic hoop σ_s (psi)	Static hoop σ_{static} (psi)	Total hoop $\sigma_{static} + \sigma_s$ (psi)	D/C	
-	(ft)	(ft)	(lbs/in)	(lbs/in)	(lbs/in)	(lbs/in)	(in)	(psi)	(psi)	(psi)	-	
5	5	32	584	1553	153	910	0.292	5706	3116	8,822	0.40	OK
4	13	24	1341	1065	397	2,366	0.278	6324	8511	14,835	0.68	OK
3	21	16	1883	768	642	3,822	0.318	6705	12019	18,724	0.85	OK
2	29	8	2208	608	887	5,278	0.426	5764	12390	18,154	0.83	OK
Base	37	0	2316	558	1131	6,734	0.495	5328	13604	18,932	0.86	OK

Required Anchoring

J =	3.14	Overturning ratio	[Eq 13-36]
Anchor =	MECH	Self-Anchoring or Mechanical	
N =	44	Number of Tension Anchors around tank perimeter	
D_{ac} =	72.0 ft	Diameter of anchor circle = $D+2x(1.0')$, anchors are spaced 1.0-ft off of tank shell	
s =	5.1 ft	Anchor spacing	
M_s =	47,323 kip-ft	Seismic overturning	[Eq 13-23]
W' =	188 kips	$W' = w_t''*D*pi$	
P_s =	55.5 kips per anchor		[Eq 3-42]
Net Tension			

1.638 0.927192

WIND DESIGN - TANK EMPTY

Wind

$V_{3s} =$	85 mph	Wind Velocity, 3-second gust [Provided]	
	Angle	Roof Type	
$C_f =$	0.60	Wind Drag Factor, lateral	Table 2
$C_{fr} =$	-0.53	Wind Drag Factor, uplift ("suction") at roof, average	
$K_z =$	1.09	Velocity pressure coeff	Table 3
$P_w =$	18.0 psf	Wind lateral pressure, ASD level	[Eq 3-1]
$P_{wr} =$	-12.3 psf	Wind roof pressure, ASD level	

Local shell plate bending / Stiffener check

$t' =$	0.275 in	Min req'd average shell PL thickness for wind [Eq 3-36]
		Avg Shell Thickness, $t' = (P_w \times D^{3/2} \times H_s / 10.625 \times 10^6) ^{2/5}$
$t_{ave} =$	0.362 in	OK

Stability check - Sliding - Wind

$\mu =$	0.58	Lower bound, Coefficient of sliding friction	
$\mu =$	0.80	Coefficient of sliding friction for wind	
$F_{up} =$	-47 kips	Net uplift concurrent with lateral load (no reduction)	
$W_{stl} =$	228 kips	Total steel weight (Roof, shells, floor PL)	
$V_{ALLOW_W} =$	75.4 kips	Sliding resistance (capacity) to wind	$V_{ALLOW_W} = \mu \times (0.6 \times W_{stl} + 0.9 \times F_{up})$
$V_{Wind} =$	45.4 kips	Driving sliding demand, $V = 0.9 \times P_w \times A_{SIDE}$	$V_{WIND} = 0.9 \times P_w \times A_{SIDE}$
$D/C =$	0.60		

Wind Sliding OK

Stability check - Overturning - Wind

$M_{ALLOW_W} =$	3,298 kip-ft	OTM resistance (capacity) to wind	$M_{ALLOW_W} = (0.6 \times W_{stl} + 0.9 \times F_{up}) \times D/2$
$M_{Wind} =$	907 kip-ft	Driving OTM demand, $M_{WIND} = V_{WIND} \times H/2$	
$D/C =$	0.28		

Wind Overturning OK

Basis for design for Stability:

ASCE 7-10, Eq 2.4.1, Eq 7, with Except 2 and $0.6W = W$
 with Exception 2 and $0.6W = W$

HELICAL PILE LAYOUT AND ANALYSIS (e = 11-in)

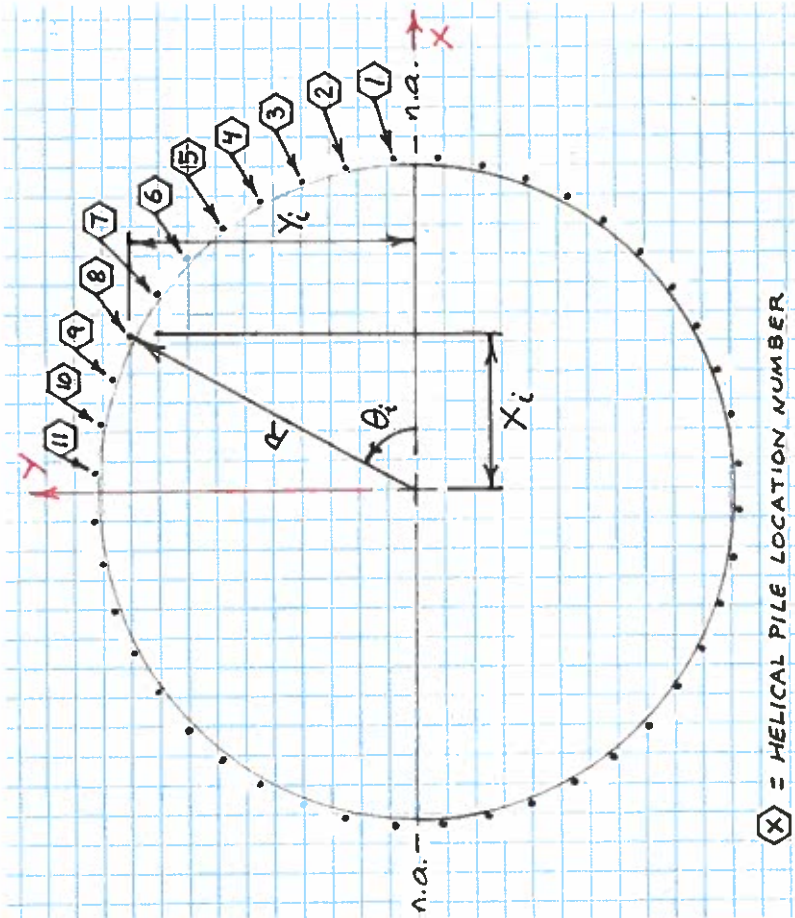

$M_s = 47,323$ kip-ft
 Tank inside radius $r_i = 420$ in
 Tank wall thickness $t = 0.541$ in
 Pile eccentricity $e = 11$ in
 $R = r_i + t + e = 35.96175$ ft
 $N = 44$
 $\Delta\theta = 8.181818$ degrees
 Pile Spacing $s = R\Delta\theta = 5.14$ ft
 Tributary dead load:
 $w_t = 913$ plf
 $D = 70$ ft
 $W/N = w_t \cdot D / N = 4.56$ kip

LEGEND:

- = USER REQUIRED INPUT
- = CALCULATED BY THE SPREAD SHEET
- = CALCULATED BY THE SPREAD SHEET (IMPORTANT VALUE TO CHECK)

(X) = HELICAL PILE LOCATION NUMBER

HELICAL PILE LOCATION NUMBER	θ_i (degrees)	$\cos\theta_i$	$X_i = (R \times \cos\theta_i)$ (ft)	PILE Area A_i (ft ²)	$X_i^2 = (R \times \cos\theta_i)^2$ (ft ²)	No of piles at X_i	$P_{working\ stress} = M_s(X_i)/l_y \times$ No. piles along ordinate at X_i (kip-ft)	$P_u = (1/0.7) \times M_s(X_i)/l_y$ (kip-ft)	$W/N =$ Tributary Dead Load to Pile (kip)	Working Stress (ASD) for helical screw anchor design		Ultimate (LRFD) for concrete design		
										$P_{S,compression} = P_{working\ stress}$ (kip)	$P_{S,tension} = P_{working\ stress}$ (kip)	$P_{S,u,compression} = P_u$ (kip)	$P_{S,u,tension} = P_u - 0.6W/N$ (kip)	
1	4.09091	1.00	35.87	1.00	1,287	2	35	49	4.56	34.62	30.06	49.46	46.72	
2	12.27273	0.98	35.14	1.00	1,235	2	34	48	4.56	33.92	29.36	48.45	45.72	
3	20.45455	0.94	33.69	1.00	1,135	2	33	46	4.56	32.52	27.96	46.46	43.72	
4	28.63636	0.88	31.56	1.00	996	2	30	44	4.56	30.47	25.90	43.52	40.78	
5	36.81818	0.80	28.79	1.00	829	2	28	40	4.56	27.79	23.22	39.70	36.96	
6	45	0.71	25.43	1.00	647	2	25	35	4.56	24.54	19.98	35.06	32.33	
7	53.18182	0.60	21.55	1.00	464	2	21	30	4.56	20.80	16.24	29.72	26.98	
8	61.36364	0.48	17.23	1.00	297	2	17	24	4.56	16.64	12.07	23.76	21.03	
9	69.54546	0.35	12.57	1.00	158	2	12	17	4.56	12.13	7.57	17.33	14.59	
10	77.72727	0.21	7.64	1.00	58	2	7	11	4.56	7.38	2.82	10.54	7.80	
11	85.90909	0.07	2.57	1.00	7	2	2	4	4.56	2.48	-2.09	3.54	0.80	
				$\Sigma =$	6,128	$4 \times \Sigma =$	24,514	$\Sigma r^4 =$						

ANCHOR CHAIR DESIGN (e = 11-in)

TOP PLATE

$P = 34.62$ kip
 $f = 3$ in
 $g = 11.5$ in
 $d = 3.5$
 $S_{allow} = 20$ ksi
 $c = 1.429758$ in
 Choos $c = 1.75$

Design load
 Distance between edge of anchor hole and free edge of top plate
 Face to face distance between vertical plates
 Diameter of helical screw anchor shaft
 Allowable local shell stress per AWWA D100-11, Section 3.8.6.1

CHAIR HEIGHT

$h = 40$ in
 $a = 13.5$ in
 $R = 420$ in
 $t = 0.541$ in
 $e = 11$ in
 $m = 0.25$ in
 $Z = 0.991608$

Chair height between top plate and bottom plates
 Top plate circumferential width
 Inside tank radius
 Tank bottom shell course thickness
 Maximum eccentricity of centerline of helical screw pile from outside face of tank wall
 Minimum bottom plate thickness
 AISI T-192, Equation 5-4

$Pe/f^2 = 1301.2609$
 $1.32Z = 1.308923$
 $1.43ah^2/RT = 135.93874$
 $(4ah)^{2.0333} = 44.041193$
 $0.031/(SQRT(Rt)) = 0.0020565$
 AISI T-192, Equation 5-3
 Allowable local shell stress per AWWA D100-11, Section 3.8.6.1

VERTICAL SIDE PLATES

$c = 1.75$ in
 $b = 18$ in
 $b_{min} = 6$ in
 $(j)_{min} = 0.5$ in
 $OR, (j)_{min} = 0.04(h-c) = 1.53$ in
 $j = 1.53$ in
 $k_{avg} = 12$ in
 $jk_{avg} = 18.36$
 $P/25 = 1.384925$
O.K. $jk > P/25$

Top plate thickness
 Top plate radial width
 Bottom plate radial width
 Side plate minimum allowable thickness
 Or, side plate minimum allowable thickness
 Site plate minimum allowable thickness
 Average side plate width

WELDS

$W_v = P/(a+2h) = 0.370301$ kip/in
 $W_H = Pe/(ah+0.667h^2) = 0.236968$ kip/in
 $W = SQRT(W_v^2 + W_H^2) = 0.439632$ kip/in
 Weld Thk 'w' = $W/9.5 = 0.046277$ in
Use 1/4-in weld

HELICAL PILE LAYOUT AND ANALYSIS (e = 12-in)

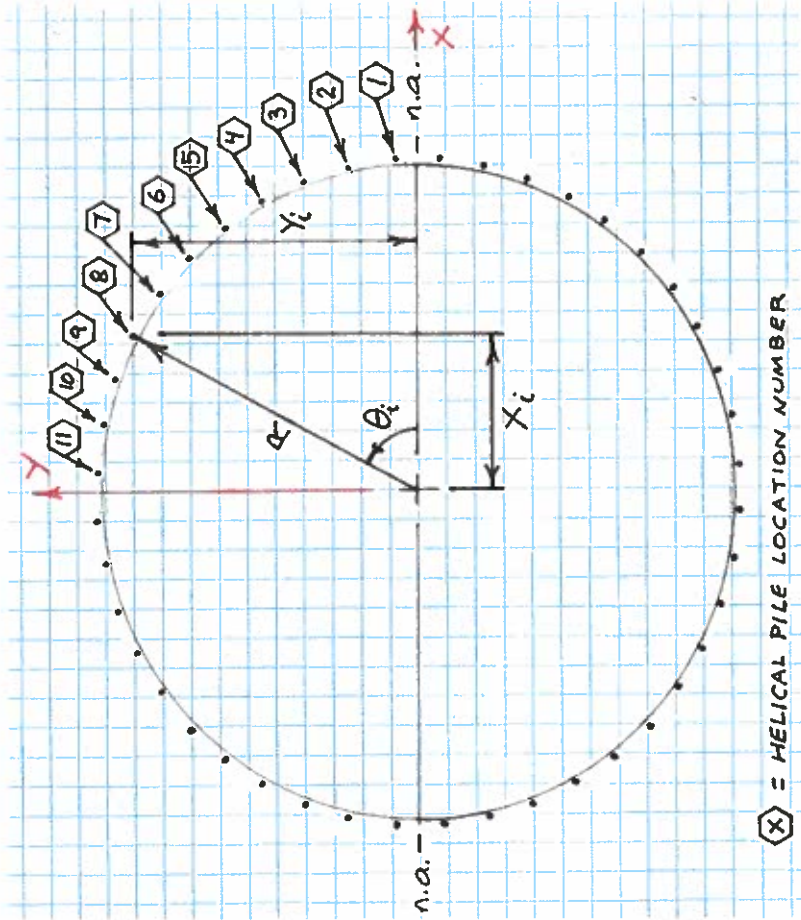

$M_s = 47,323$ kip-ft
 Tank inside radius $r_i = 420$ in
 Tank wall thickness $t = 0.541$ in
 Pile eccentricity $e = 12$ in
 $R = r_i + t + e = 36.04508$ ft
 $N = 44$
 $\Delta\theta_i = 8.181818$ degrees
 $= 5.15$ ft
 Pile Spacing $s = R\Delta\theta_i$
 tributary dead load:
 $w_i = 913$ plf
 $D = 70$ ft
 $W/N = w_i \cdot D \cdot \pi/N = 4.56$ kip

LEGEND:
 = USER REQUIRED INPUT
 = CALCULATED BY THE SPREAD SHEET
 = CALCULATED BY THE SPREAD SHEET (IMPORTANT VALUE TO CHECK)

(X) = HELICAL PILE LOCATION NUMBER

HELICAL PILE LOCATION NUMBER	θ_i (degrees)	$\cos\theta_i$	$X_i = (R \times \cos\theta_i)$ (ft)	PILE Area A_i (ft ²)	$X_i^2 = (R \times \cos\theta_i)^2$ (ft ⁴)	No of piles at X_i	$P_{working\ stress} = M_s(X_i)/l_y \times$ No. piles along ordinate at X_i (kip-ft)	$P_u = (1/0.7) \times M_s(X_i)/l_y$ (kip-ft)	$W/N =$ Tributary Dead Load to Pile (kip)	$P_{S,compression} = P_{working\ stress}$ (kip)	$P_{S,tension} = P_{working\ stress} - W/N$ (kip)	$P_{S,u,compression} = P_u$ (kip)	$P_{S,u,tension} = P_u - 0.6W/N$ (kip)
1	4.09091	1.00	35.95	1.00	1,293	2	35	49	4.56	34.54	29.98	49.35	46.61
2	12.27273	0.98	35.22	1.00	1,241	2	34	48	4.56	33.84	29.28	48.34	45.60
3	20.45455	0.94	33.77	1.00	1,141	2	32	46	4.56	32.45	27.88	46.35	43.62
4	28.63636	0.88	31.64	1.00	1,001	2	30	43	4.56	30.40	25.83	43.42	40.68
5	36.81818	0.80	28.86	1.00	833	2	28	40	4.56	27.72	23.16	39.61	36.87
6	45	0.71	25.49	1.00	650	2	24	35	4.56	24.49	19.92	34.98	32.25
7	53.18182	0.60	21.60	1.00	467	2	21	30	4.56	20.75	16.19	29.65	26.91
8	61.36364	0.48	17.27	1.00	298	2	17	24	4.56	16.60	12.03	23.71	20.97
9	69.54546	0.35	12.60	1.00	159	2	12	17	4.56	12.10	7.54	17.29	14.55
10	77.72727	0.21	7.66	1.00	59	2	7	11	4.56	7.36	2.80	10.52	7.78
11	85.90909	0.07	2.57	1.00	7	2	2	4	4.56	2.47	-2.09	3.53	0.79
				$\Sigma =$									
					6,157								
					24,627								

$l_x = l_y = 4 \times \Sigma =$
 ft^4

ANCHOR CHAIR DESIGN (e = 12-in)

TOP PLATE

$P = 34.54$ kip Design load
 $f = 3$ in Distance between edge of anchor hole and free edge of top plate
 $g = 11.5$ in Face to face distance between vertical plates
 $d = 3.5$ Diameter of helical screw anchor shaft
 $S_{allow} = 20$ ksi Allowable local shell stress per AWWA D100-11, Section 3.8.6.1
 $c = 1.428104$ in
 Choos $c = 1.75$

CHAIR HEIGHT

$h = 40$ in Chair height between top plate and bottom plates
 $a = 13.5$ in Top plate circumferential width
 $R = 420$ in Inside tank radius
 $t = 0.541$ in Tank bottom shell course thickness
 $e = 12$ in Maximum eccentricity of centerline of helical screw pile from outside face of tank wall
 $m = 0.25$ in Minimum bottom plate thickness
 $Z = 0.991608$ AISI T-192, Equation 5-4
 $Pe/t^2 = 1416.2754$
 $1.32Z = 1.308923$
 $1.43ah^2/rt = 135.93874$
 $(4ah^2)^{0.333} = 44.041193$
 $S = 13.21265$ ksi $0.031/(SQRT(Rt)) = 0.0020565$ AISI T-192, Equation 5-3
 $S_{allow} = 20$ ksi Allowable local shell stress per AWWA D100-11, Section 3.8.6.1
O.K. $S < Allowable$

VERTICAL SIDE PLATES

$c = 1.75$ in Top plate thickness
 $b = 18$ in Top plate radial width
 $b_{min} = 6$ in Bottom plate radial width
 $(j)_{min} = 0.5$ in Side plate minimum allowable thickness
 OR, $(j)_{min} = 0.04(h-c) = 1.53$ in Or, side plate minimum allowable thickness
 $j = 1.53$ in Site plate minimum allowable thickness
 $k_{avg} = 12$ in Average side plate width
 $jk_{avg} = 18.36$
 $P/25 = 1.381723$
O.K. $jk > P/25$

WELDS

$W_v = P/(a+2h) = 0.369445$ kip/in
 $W_H = Pe/(ah+0.667h^2) = 0.257912$ kip/in
 $W = SQRT(W_v^2+W_H^2) = 0.450564$ kip/in
 Weld Thk $w' = W/9.5 = 0.047428$ in
Use 1/4-in weld

HELICAL PILE LAYOUT AND ANALYSIS (e = 13-in)

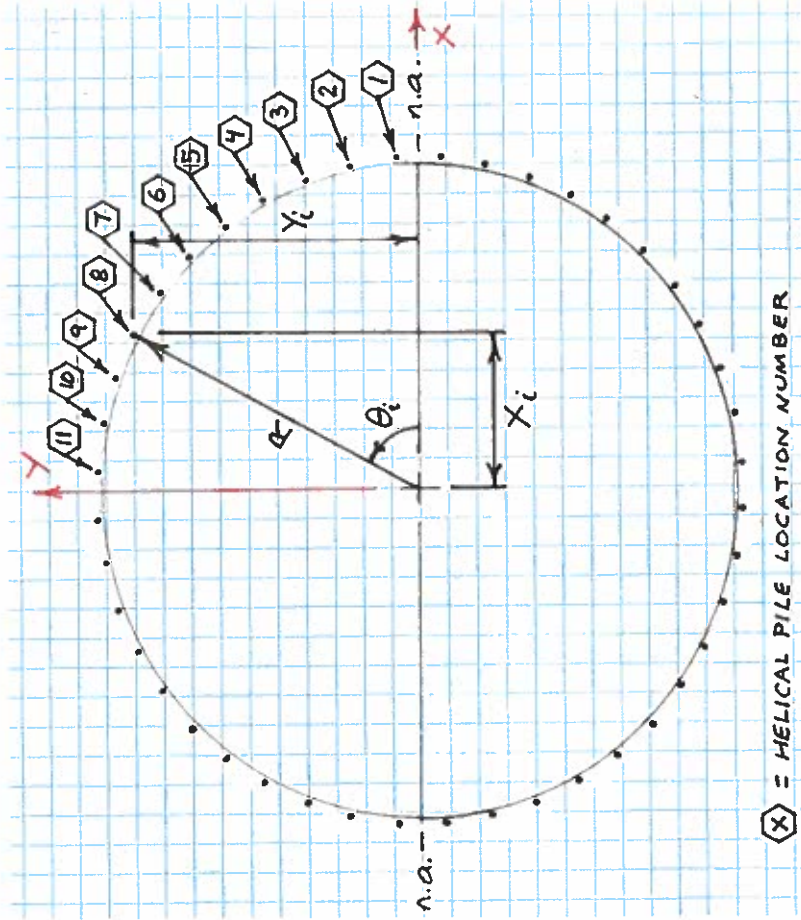

$M_s = 47,323$ kip-ft
 Tank inside radius $r_i = 420$ in
 Tank wall thickness $t = 0.541$ in
 Pile eccentricity $e = 13$ in
 $R = r_i + t + e = 36.12842$ ft
 $N = 44$
 $\Delta\theta_i = 8.181818$ degrees
 5.16 ft
 Pile Spacing $s = R\Delta\theta_i = 5.16$ ft
 tributary dead load:
 $w_i = 913$ plf
 $D = 70$ ft
 $W/N = w_i \cdot D \cdot \pi / N = 4.56$ kip

LEGEND:
 = USER REQUIRED INPUT
 = CALCULATED BY THE SPREAD SHEET
 = CALCULATED BY THE SPREAD SHEET (IMPORTANT VALUE TO CHECK)

(X) = HELICAL PILE LOCATION NUMBER

HELICAL PILE LOCATION NUMBER	θ_i (degrees)	$\cos\theta_i$	$X_i = (R \times \cos\theta_i)$ (ft)	PILE Area A_i (ft ²)	$X_i^2 = (R \times \cos\theta_i)^2$ (ft ²)	No of piles at X_i	$P_{working\ stress} = M_s(X_i)/l_y \times$ No. piles along ordinate at X_i (kip-ft)	$P_u = (1/0.7) \times M_s(X_i)/l_y$ (kip-ft)	W/N = Tributary Dead Load to Pile (kip)	Working Stress (ASD) for helical screw anchor design		Ultimate (LRFD) for concrete design		
										$P_{S,compression} = P_{working\ stress}$ (kip)	$P_{S,tension} = P_{working\ stress}$ (kip)	$P_{S,u,compression} = P_u$ (kip)	$P_{S,u,tension} = P_u - 0.6W/N$ (kip)	
1	4.09091	1.00	36.04	1.00	1,299	2	34	49	4.56	34.46	29.90	49.23	46.50	
2	12.27273	0.98	35.30	1.00	1,246	2	34	48	4.56	33.76	29.20	48.23	45.49	
3	20.45455	0.94	33.85	1.00	1,146	2	32	46	4.56	32.37	27.81	46.25	43.51	
4	28.63636	0.88	31.71	1.00	1,005	2	30	43	4.56	30.33	25.76	43.32	40.58	
5	36.81818	0.80	28.92	1.00	836	2	28	40	4.56	27.66	23.10	39.51	36.78	
6	45	0.71	25.55	1.00	653	2	24	35	4.56	24.43	19.87	34.90	32.16	
7	53.18182	0.60	21.65	1.00	469	2	21	30	4.56	20.71	16.14	29.58	26.84	
8	61.36364	0.48	17.31	1.00	300	2	17	24	4.56	16.56	12.00	23.66	20.92	
9	69.54546	0.35	12.63	1.00	159	2	12	17	4.56	12.07	7.51	17.25	14.51	
10	77.72727	0.21	7.68	1.00	59	2	7	10	4.56	7.34	2.78	10.49	7.75	
11	85.90909	0.07	2.58	1.00	7	2	2	4	4.56	2.46	-2.10	3.52	0.78	
					$\Sigma = 6,185$									
					$I_x = I_y = 4 \times \Sigma = 24,741$									

ANCHOR CHAIR DESIGN (e = 13-in)

TOP PLATE

$P = 34.46$ kip Design load
 $f = 3$ in Distance between edge of anchor hole and free edge of top plate
 $g = 11.5$ in Face to face distance between vertical plates
 $d = 3.5$ Diameter of helical screw anchor shaft
 $S_{allow} = 20$ ksi Allowable local shell stress per AWWA D100-11, Section 3.8.6.1
 $c = 1.426456$ in
 Choos $c = 1.75$

CHAIR HEIGHT

$h = 40$ in Chair height between top plate and bottom plates
 $a = 13.5$ in Top plate circumferential width
 $R = 420$ in Inside tank radius
 $t = 0.541$ in Tank bottom shell course thickness
 $e = 13$ in Maximum eccentricity of centerline of helical screw pile from outside face of tank wall
 $m = 0.25$ in Minimum bottom plate thickness
 $Z = 0.991608$ AISI T-192, Equation 5-4
 $Pe/t^2 = 1530.7594$
 $1.32Z = 1.308923$
 $1.43ah^2/Rt = 135.93874$
 $(4ah)^{0.333} = 44.041193$
 $S = 0.031/(SQRT(Rt)) = 0.0020565$ ksi
 $S_{allow} = 20$ ksi
O.K. $S < Allowable$
 Allowable local shell stress per AWWA D100-11, Section 3.8.6.1

VERTICAL SIDE PLATES

$c = 1.75$ in Top plate thickness
 $b = 18$ in Top plate radial width
 $b_{min} = 6$ in Bottom plate radial width
 $(j)_{min} = 0.5$ in Side plate minimum allowable thickness
 OR, $(j)_{min} = 0.04(h-c) = 1.53$ in Or, side plate minimum allowable thickness
 $j = 1.53$ in Site plate minimum allowable thickness
 $k_{avg} = 12$ in Average side plate width
 $jk_{avg} = 18.36$
 $P/25 = 1.378536$
O.K. $jk > P/25$

WELDS

$W_v = P/(a+2h) = 0.368593$ kip/in
 $W_H = Pe/(ah+0.667h^3) = 0.278761$ kip/in
 $W = SQRT(W_v^2 + W_H^2) = 0.462134$ kip/in
 Weld Thk 'w' = $W/9.5 = 0.048646$ in
Use 1/4-in weld

HELICAL PILE LAYOUT AND ANALYSIS (e = 13-in, at Manway)

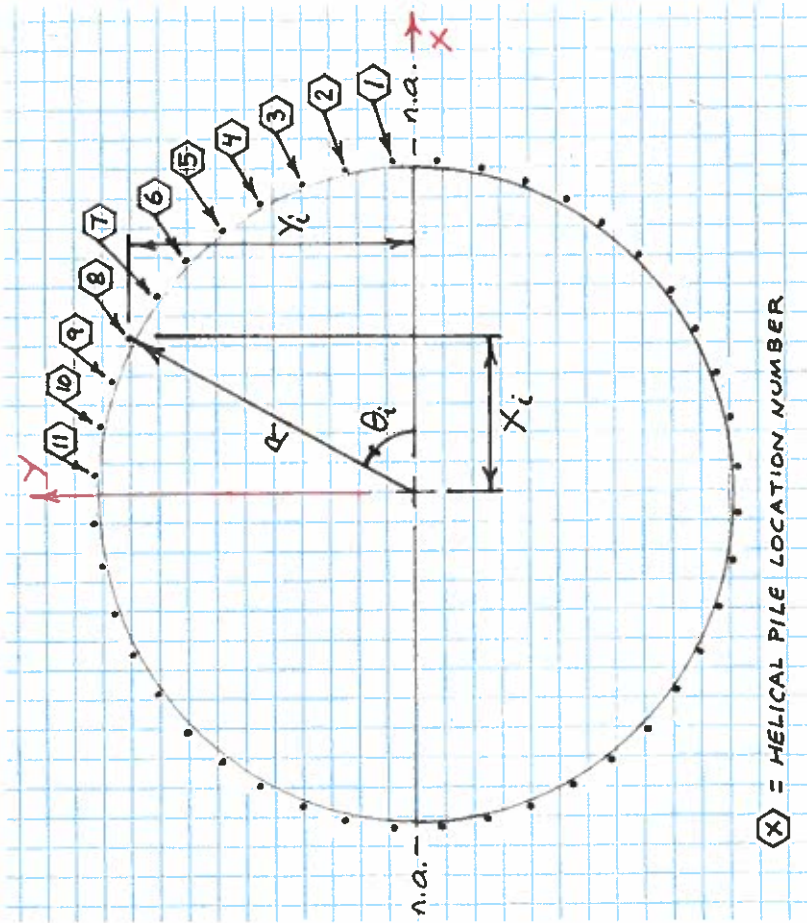

$M_s = 47.323$ kip-ft
 Tank inside radius $r_i = 420$ in
 Tank wall thickness $t = 0.541$ in
 Pile eccentricity $e = 13$ in
 $R = r_i + t + e = 36.12842$ ft
 $N = 44$
 $\Delta\theta_i = 8.181818$ degrees
 $= 5.16$ ft
 Pile Spacing $s = R\Delta\theta_i = 5.16$ ft
 tributary dead load:
 $w_i = 913$ plf
 $D = 70$ ft
 $W/N = w_r \cdot D \cdot \pi / N = 4.56$ kip

LEGEND:
 = USER REQUIRED INPUT
 = CALCULATED BY THE SPREAD SHEET
 = CALCULATED BY THE SPREAD SHEET (IMPORTANT VALUE TO CHECK)

(X) = HELICAL PILE LOCATION NUMBER

HELICAL PILE LOCATION NUMBER	θ_i (degrees)	$\cos\theta_i$	$X_i = (R \times \cos\theta_i)$ (ft)	PILE Area A_i (ft ²)	$X_i^2 = (R \times \cos\theta_i)^2$ (ft ²)	No of piles at X_i	$P_{working\ stress} = M_s(X_i)/(l_y \times \text{No. piles along ordinate at } X_i)$ (kip-ft)	$P_u = (1/0.7) \times M_s(X_i)/l_y$ (kip-ft)	$W/N = \text{Tributary Dead Load to Pile}$ (kip)	$P_{S, compression} = P_{working\ stress}$ (kip)	$P_{S, tension} = P_{working\ stress} - W/N$ (kip)	$P_{S, u, compression} = P_u$ (kip)	$P_{S, u, tension} = P_u - 0.6W/N$ (kip)
1	7.094	0.99	35.85	1.00	1,285	2	34	49	4.56	34.36	29.80	49.09	46.35
2	12.2727	0.98	35.30	1.00	1,246	2	34	48	4.56	33.83	29.27	48.33	45.60
3	20.45452	0.94	33.85	1.00	1,146	2	32	46	4.56	32.44	27.88	46.35	43.61
4	28.63634	0.88	31.71	1.00	1,005	2	30	43	4.56	30.39	25.83	43.41	40.68
5	36.81815	0.80	28.92	1.00	836	2	28	40	4.56	27.72	23.16	39.60	36.86
6	44.99997	0.71	25.55	1.00	653	2	24	35	4.56	24.48	19.92	34.98	32.24
7	53.18179	0.60	21.65	1.00	469	2	21	30	4.56	20.75	16.19	29.64	26.91
8	61.36361	0.48	17.31	1.00	300	2	17	24	4.56	16.59	12.03	23.71	20.97
9	69.54543	0.35	12.63	1.00	159	2	12	17	4.56	12.10	7.54	17.29	14.55
10	77.72725	0.21	7.68	1.00	59	2	7	11	4.56	7.36	2.80	10.51	7.78
11	85.90906	0.07	2.58	1.00	7	2	2	4	4.56	2.47	-2.09	3.53	0.79
			$\Sigma =$										
					6,172								
					24,688								
					ft ⁴								
					ft ⁴								

ANCHOR CHAIR DESIGN (e = 13-in, at Manway)

TOP PLATE

P = 34.36 kip Design load
f = 3 in Distance between edge of anchor hole and free edge of top plate
g = 11.5 in Face to face distance between vertical plates
d = 3.5 Diameter of helical screw anchor shaft
S_{allow} = 20 ksi Allowable local shell stress per AWWA D100-11, Section 3.8.6.1
c = 1.424327 in
Choos c = 1.75

CHAIR HEIGHT

h = 40 in Chair height between top plate and bottom plates
a = 13.5 in Top plate circumferential width
R = 420 in Inside tank radius
t = 0.541 in Tank bottom shell course thickness
e = 13 in Maximum eccentricity of centerline of helical screw pile from outside face of tank wall
m = 0.25 in Minimum bottom plate thickness
Z = 0.991608 AISI T-192, Equation 5-4
 $Pe/t^2 = 1526.1938$
 $1.32Z = 1.308923$
 $1.43ah^2/RT = 135.93874$
 $(4ah^2)^{0.333} = 44.041193$
S = 14.23809 ksi $0.031/(SQRT(Rt)) = 0.0020565$ AISI T-192, Equation 5-3
S_{allow} = 20 ksi Allowable local shell stress per AWWA D100-11, Section 3.8.6.1
O.K. S < Allowable

VERTICAL SIDE PLATES

c = 1.75 in Top plate thickness
b = 18 in Top plate radial width
b_{min} = 6 in Bottom plate radial width
(j)_{min} = 0.5 in Side plate minimum allowable thickness
OR, (j)_{min} = 0.04(h-c) = 1.53 in Or, side plate minimum allowable thickness
j = 1.53 in Side plate minimum allowable thickness
k_{avg} = 12 in Average side plate width
jk_{avg} = 18.36
P/25 = 1.374424
O.K. jk > P/25

WELDS

W_v = P/(a+2h) = 0.367493 kip/in
W_{rt} = Pe/(ah+0.667h²) = 0.277929 kip/in
W = SQRT(W_v²+W_{rt}²) = 0.460756 kip/in
Weld Thk 'w' = W/9.5 = 0.048501 in
Use 1/4-in weld

Client	Job Number	Sheet of
Project	Calcs by	Date
Subject	Checked by	Date

Pile Cap Beam Design

Design of supporting CIDH piles

See figure on following page for layout of beam and piles.

$$\theta = 36^\circ \text{ to } \theta = 59^\circ$$

$$s = r\theta = 35' (23^\circ (\pi/180^\circ)) = 14.0'$$

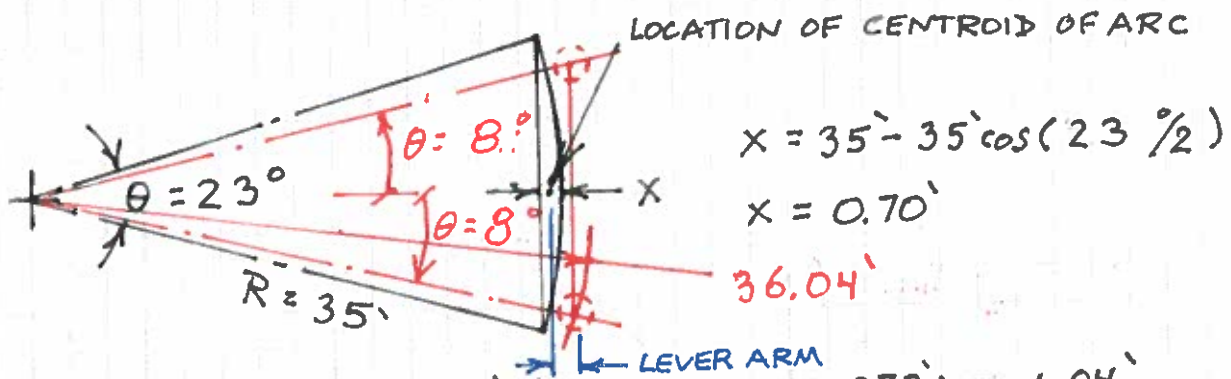

$$X = 35' - 35' \cos(23^\circ / 2)$$

$$X = 0.70'$$

$$\text{LEVER ARM} = 36.04' \cos(8^\circ) - (35' - \frac{0.70'}{2}) = 1.04'$$

$$\text{UPLIFT FORCE AT CENTER OF ARC} = 23^\circ \left(\frac{34.62^k}{8.1818'} \right) = 97.3^k \text{ (conservative)}$$

$$\text{MOMENT ON PILE HEAD} = \frac{1}{2} (97.3^k) 1.04' = 50.6^k \text{ ASD}$$

$$\text{VERTICAL FORCE ON PILE HEAD} = \pm \frac{1}{2} (97.3^k) = 48.7^k \text{ ASD}$$

$$P_u = 48.7^k \times 1.43 = 69.6^k \text{ LRFD}$$

$$T_u = 50^k \times 1.43 = 72.4^k \text{ LRFD}$$

$$= 868^k$$

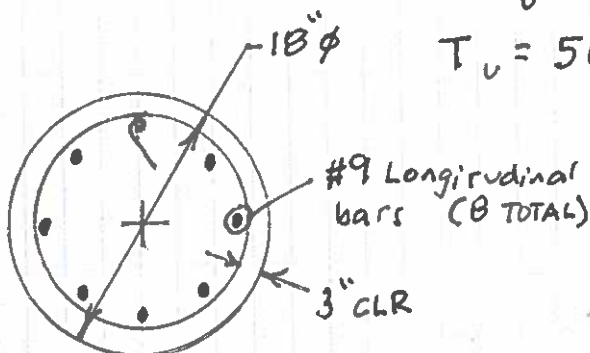

SK-5

North Arrow

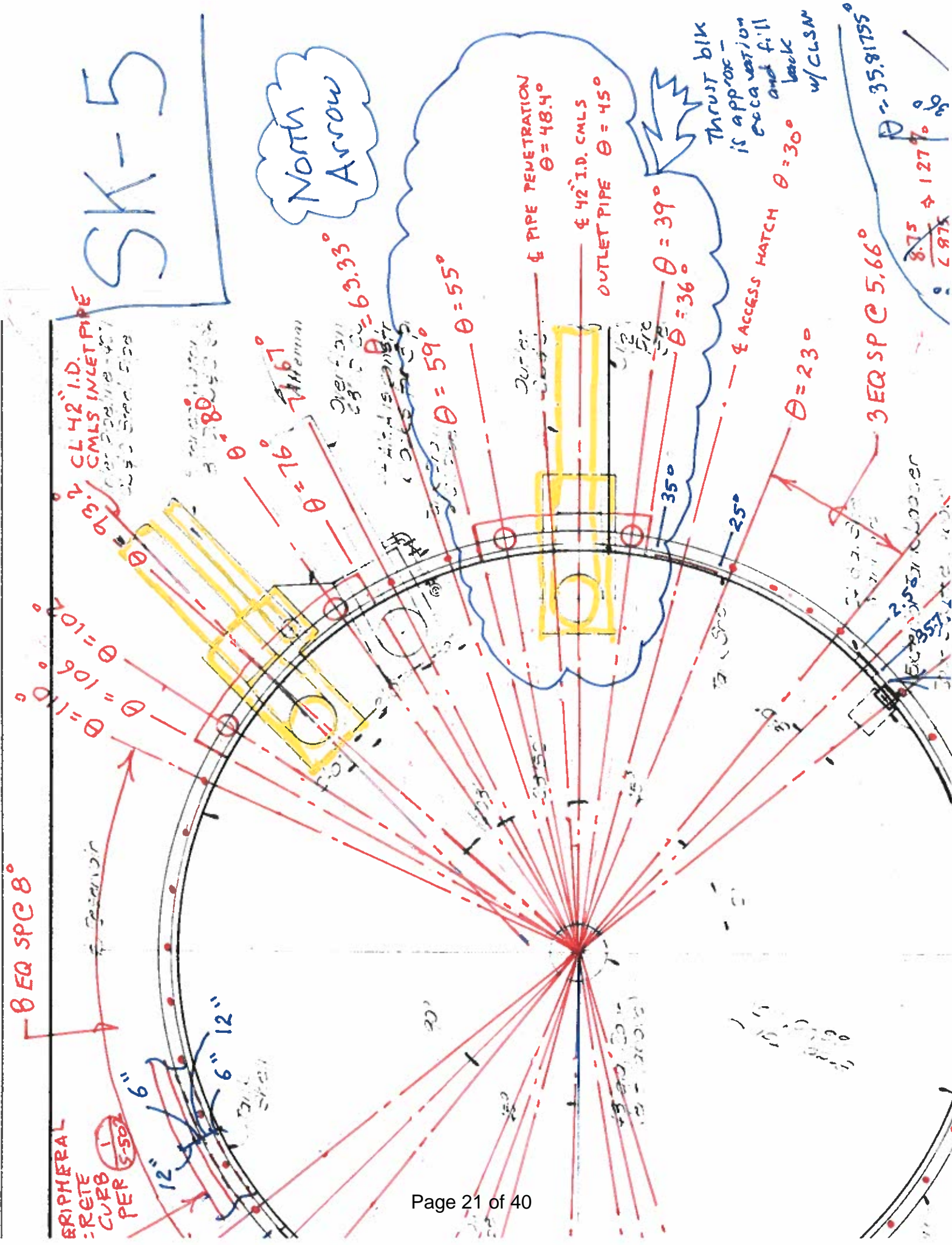

Thrust blk is approx excavation and fill back w/ CLSN

3 EQ SP @ 5.66"

$$\frac{8.75}{0.97} = 127.9$$

$\theta = 35.81755^\circ$

Client	Job Number	Sheet .. of ..
Project	Calcs by	Date
Subject	Checked by	Date

Per the attached SAP output
 @ $P_v = +69.6 \text{ k}$ (Tension)

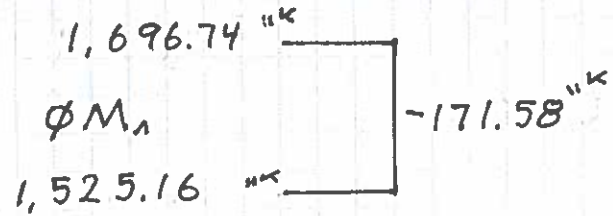
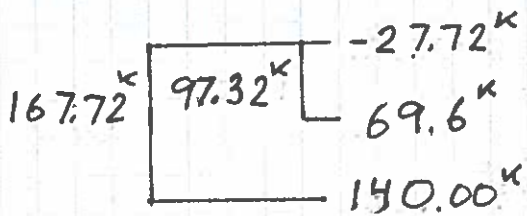

$$\phi M_n = 1,696.74 \text{ k} - 171.58 \text{ k} \left(\frac{97.32 \text{ k}}{167.72 \text{ k}} \right) = 1,597 \text{ k}$$

$$M_u = 858 \text{ k} < \phi M_n = 1,597 \text{ k}$$

@ $P_v = -69.6 \text{ k}$ (Compression)

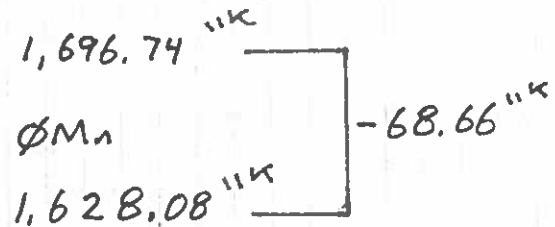
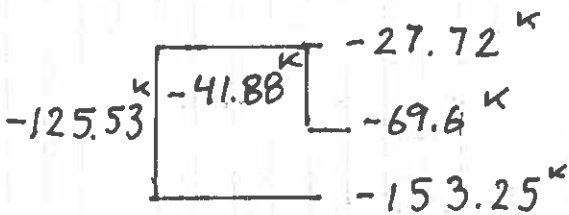

$$\phi M_n = 1,696.74 \text{ k} - 68.66 \text{ k} \left(\frac{-41.88 \text{ k}}{-125.53 \text{ k}} \right) = 1,674 \text{ k}$$

$$M_u = 858 \text{ k} < \phi M_n = 1,674 \text{ k}$$

O.K.

CIDH PILE INTERACTION DIAGRAM:

Interaction Surface (ACI 318-14)

Edit

	P	M2	M3
1	-682.4719	0	0
2	-682.4719	0	560.0666
3	-632.9113	0	990.2579
4	-511.1714	0	1333.2658
5	-353.1888	0	1545.2535
6	-153.2484	0	1628.0755
7	-27.7201	0	1696.7365
8	140.0079	0	1525.1605
9	316.9694	0	744.9339
10	404.864	0	221.1981
11	432	0	0
12			
13			
14			
15			
16			
17			

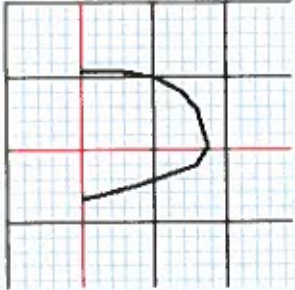
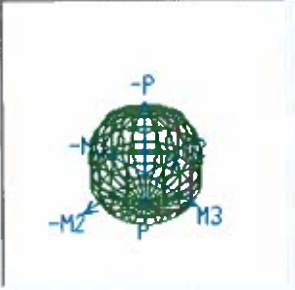
Design-Code Curve
 Fiber-Model Curve

Design Options

phi
 no phi
 no phi with fy increase

3D View

Plan: 315

Elevation: 35

3d MM PM3 PM2

Show Design-Code Results
 Show Fiber-Model Results

Done

Curve 1
Angle 0



SAP2000 Section Designer - CIDH PILE

File Edit View Define Draw Select Display Options Help

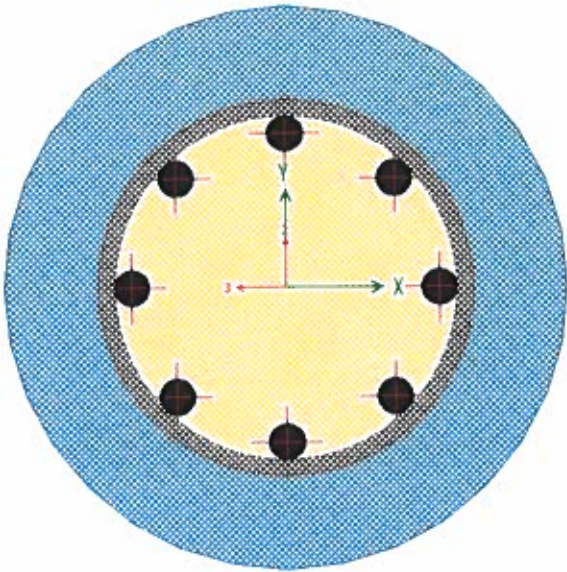

Ready X=1.777 Y=1.33

Client	Job Number	Sheet .. of ..
Project	Calcs by	Date
Subject	Checked by	Date

Pile Cap Beam Design

Design of supporting CIDH piles

See figure on following page for layout of beam and piles.

$\theta = 76^\circ$ TO $\theta = 106^\circ$
 $s = r\theta = 35'(30^\circ (\pi/180^\circ)) = 18.3'$

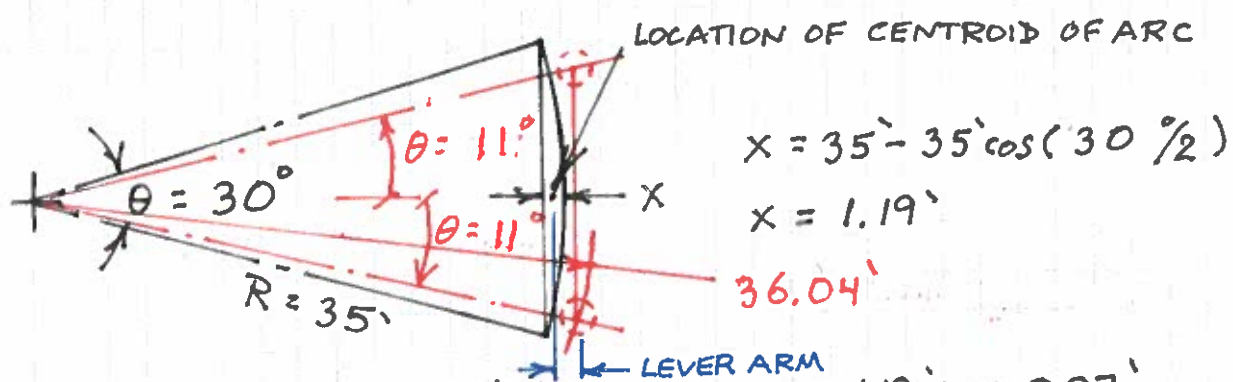

LEVER ARM = $36.04' \cos(11^\circ) - (35' - \frac{1.19'}{2}) = 0.97'$
 UPLIFT FORCE AT CENTER OF ARC = $30^\circ (\frac{34.62^k}{8.1818^\circ}) = 127^k$ (conservative)
 MOMENT ON PILE HEAD = $\frac{1}{2} (127^k) 0.97' = 61.6^k$ ASD
 VERTICAL FORCE ON PILE HEAD = $\pm \frac{1}{2} (127^k) = 63.5^k$ ASD

$P_v = 63.5^k \times 1.43 = 90.8^k$ LRFD
 $T_v = 61.6^k \times 1.43 = 88.1^k$ LRFD
 $= 1,057^k$

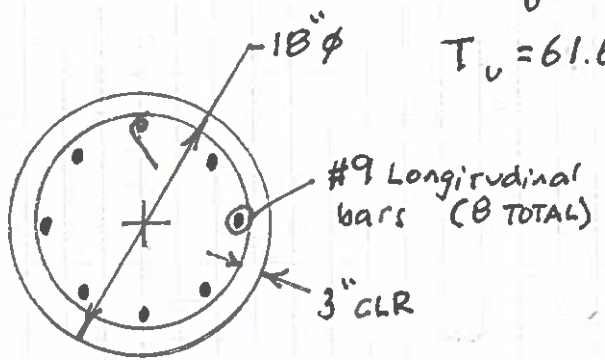



Client	Job Number	Sheet ... of ...
Project	Calcs by	Date
Subject	Checked by	Date

Per the attached SAP output
 @ $P_v = +90.8 \text{ k}$ (Tension)

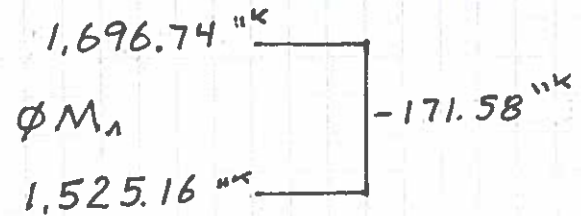
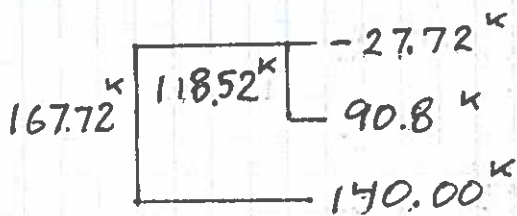

$$\phi M_n = 1696.74 \text{ k} - 171.58 \text{ k} \left(\frac{118.52 \text{ k}}{167.72 \text{ k}} \right) = 1,575 \text{ k}$$

$$M_v = 1,040 \text{ k} < \phi M_n = 1,575 \text{ k}$$

@ $P_v = -90.8 \text{ k}$ (Compression)

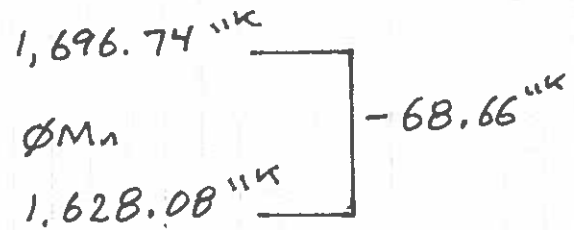
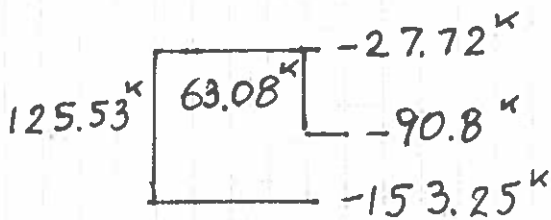

$$\phi M_n = 1,696.74 \text{ k} - 68.66 \text{ k} \left(\frac{63.08 \text{ k}}{125.53 \text{ k}} \right) = 1,662 \text{ k}$$

$$M_v = 1,040 \text{ k} < \phi M_n = 1,662 \text{ k}$$

O.K.

CIDH PILE INTERACTION DIAGRAM:

Interaction Surface (ACI 318-14)

Edit

	P	M2	M3
1	-682.4719	0	0
2	-682.4719	0	560.0666
3	-632.9113	0	990.2579
4	-511.1714	0	1333.2658
5	-353.1888	0	1545.2535
6	-153.2484	0	1628.0755
7	-27.7201	0	1696.7365
8	140.0079	0	1525.1605
9	316.9694	0	744.9339
10	404.864	0	221.1981
11	432	0	0
12			
13			
14			
15			
16			
17			

Design-Code Curve
 Fiber-Model Curve

Design Options

phi
 no phi
 no phi with fy increase

3D View

Plan: 315

Elevation: 35

3d MM PM3 PM2

Show Design-Code Results
 Show Fiber-Model Results

Done

Curve 1
Angle 0

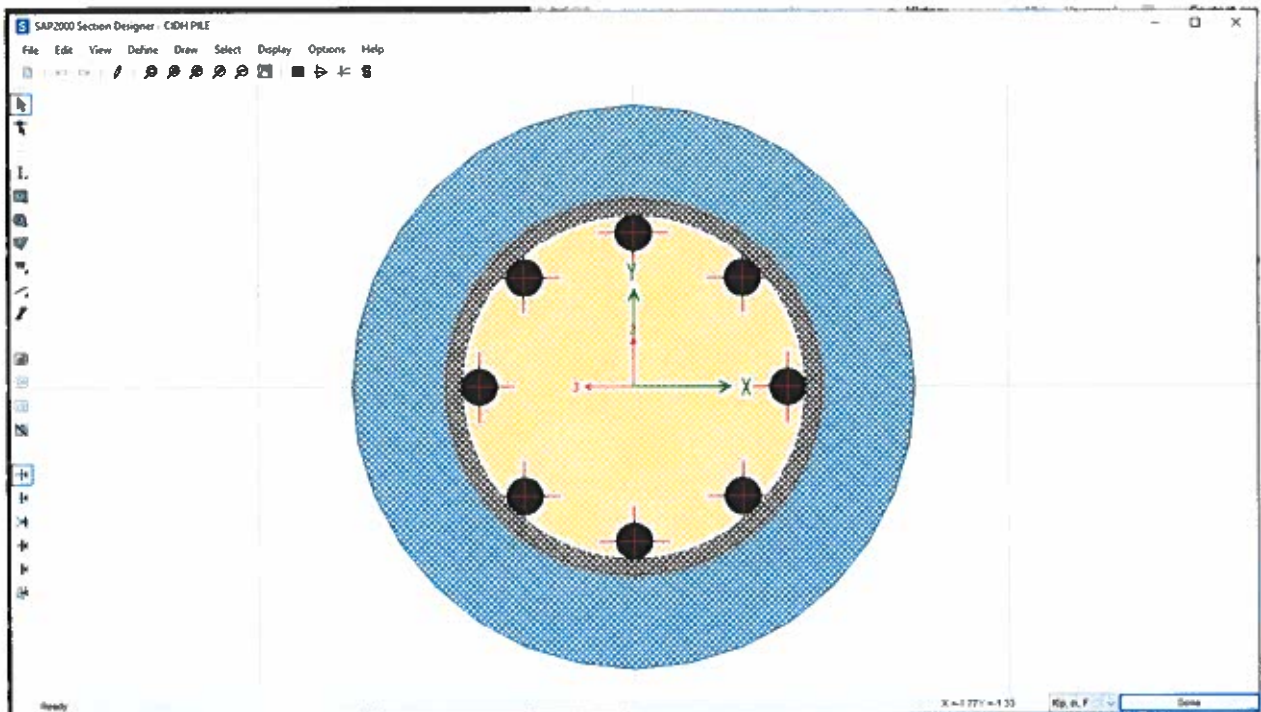

Client	Job Number	Sheet of
Project	Calcs by	Date
Subject	Checked by	Date

Pile Cap Beam Design

Design of supporting CIDH piles

See figure on following page for layout of beam and piles.

$\theta = 206^\circ$ to $\theta = 240^\circ$
 $s = r\theta = 35'(34^\circ (\pi/180^\circ)) = 20.7'$

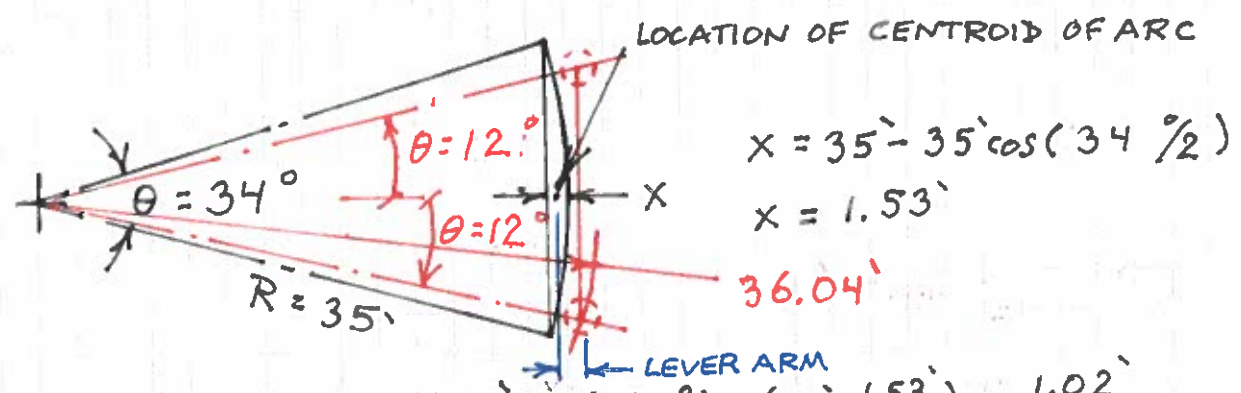

LEVER ARM = $36.04' \cos(12^\circ) - (35' - \frac{1.53'}{2}) = 1.02'$
 UPLIFT FORCE AT CENTER OF ARC = $34^\circ (\frac{34.62^k}{8.1818^\circ}) = 144^k$ (conservative)
 MOMENT ON PILE HEAD = $\frac{1}{2} (144^k) 1.02' = 73.44^k$ ASD
 VERTICAL FORCE ON PILE HEAD = $\pm \frac{1}{2} (144^k) = 72^k$ ASD

$P_u = 72^k \times 1.43 = 101.5^k$ LRFD
 $T_u = 73.44^k \times 1.43 = 105^k$ LRFD
 $= 1260^k$

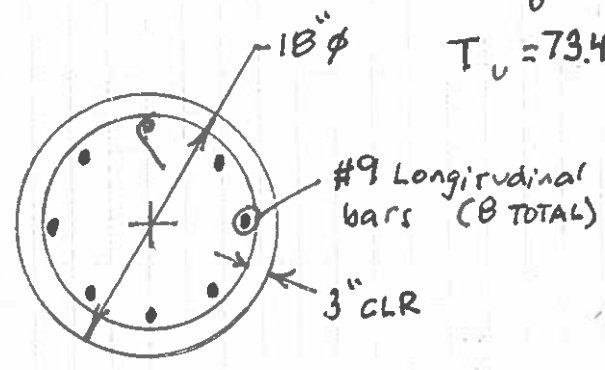

Client	Job Number	Sheet ... of ...
Project	Calcs by	Date
Subject	Checked by	Date

Per the attached SAP output

@ $P_u = +101.5 \text{ k}$ (Tension)



$$\phi M_n = 1,696.74 \text{ k} - 171.58 \text{ k} \left(\frac{129.22 \text{ k}}{167.72 \text{ k}} \right) = 1,565 \text{ k}$$

$$M_u = 1,242 \text{ k} < \phi M_n = 1,565 \text{ k}$$

@ $P_u = -101.5 \text{ k}$ (Compression)

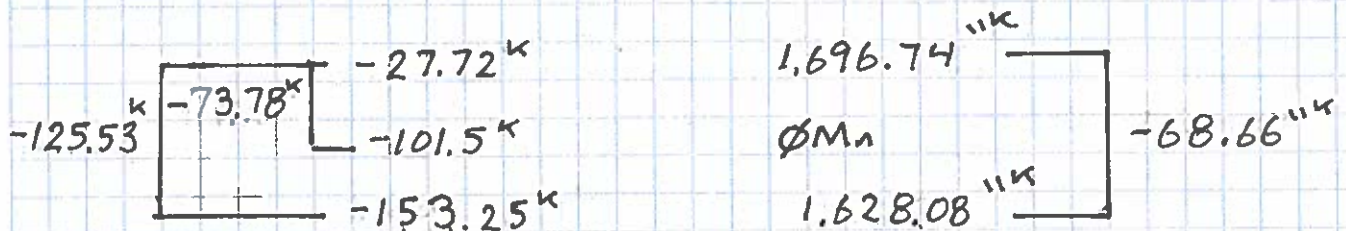

$$\phi M_n = 1,696.74 \text{ k} - 68.66 \text{ k} \left(\frac{-73.78 \text{ k}}{-125.53 \text{ k}} \right) = 1,656 \text{ k}$$

$$M_u = 1,242 \text{ k} < \phi M_n = 1,656 \text{ k}$$

O.K.

Client	Job Number	Sheet	of
Project	Calcs by	Date	
Subject	Checked by	Date	

Design of beam for flexure and shear

Circumferentially

$$s = r\theta = 36' (2 \times 12.27^\circ) \left(\frac{\pi}{180^\circ} \right) = 15.42'$$

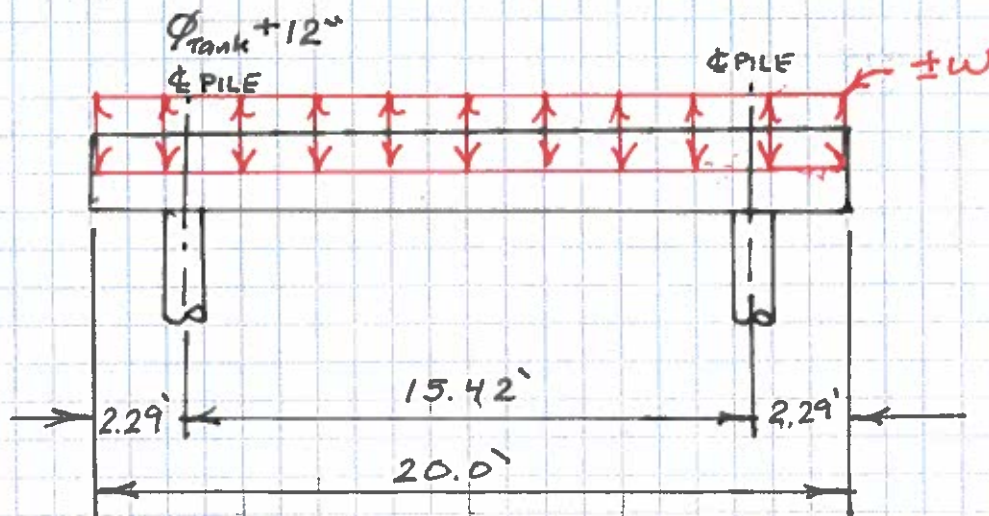

$$w = \frac{34.16^k}{8.1818^\circ} (32.73^\circ) \left(\frac{1}{20'} \right) = 6.83 \text{ k/ft}, \quad w_u = \frac{w}{0.707} = 9.7 \text{ k/ft}$$

$$M_u^+ = w_u \frac{L^2}{8} = 9.7 \text{ k/ft} \frac{(15.42')^2}{8} = 288 \text{ k} = 3460 \text{ k-in}$$

$$M_u^- = w_u \frac{L^2}{12} = 192 \text{ k} = 2,306 \text{ k-in}$$

$$V_u = w_u \frac{L}{2} = 74.8 \text{ k}$$

TORSION BEAM DESIGN

LEGEND:

- = USER REQUIRED INPUT
- = CALCULATED BY THE SPREAD SHEET
- = CALCULATED BY THE SPREAD SHEET (IMPORTANT VALUE TO CHECK)

depth of section 'h' = 24 in $\phi_{flexure}$ = 0.9 hoop bar diameter = 0.625 in f'_c = 4,000 psi
width of section 'b_w' = 30 in ϕ_{shear} = 0.9 longitudinal bar diameter = 1.00 in f_y = 60,000 psi
hoop size = 0.625 in $\phi_{torsion}$ = 0.75 clear cover = 2.00 in f_y = 60,000 psi
cover = 2 in λ = 1.00 (NWC)

DESIGN FOR FLEXURE

$(M_u)' = 3460$ in-kip
 $(A_s)_{bot\ bars} = 4$ in²
 $d = 21.688$ in
 $\phi(A_s)_{bot\ bars} f_y (d - 0.59 A_s f_y / (f'_c b)) = 4,430$ in-kip
DCR = 0.78 O.K.
 $(M_u)' = 2306$ in-kip
 $(A_s)_{top\ bars} = 4$ in²
 $\phi(A_s)_{top\ bars} f_y (d - 0.59 A_s f_y / (f'_c b)) = 4,430$ in-kip
DCR = 0.52 O.K.

DESIGN FOR SHEAR

$V_u = 74.8$ kip
 $A_v = 0.2$ in²
 $s = 4$ in
 $V_c = 2\lambda \sqrt{f'_c} b_w d = 82$ kip
 $V_s = A_v f_y d / s = 65$ kip
 $\phi(V_c + V_s) = 111$ kip
DCR = 0.68 O.K.
 $A_v / s = 0.0500$

DESIGN FOR TORSION

Threshold Torsion

$T_u = 1093$ in-kip
 $A_{cp} = 720$ in²
 $P_{cp} = 108$ in
 303.58 in-kip
 $\phi T_u = 228$ in-kip
DCR = 4.80 N.G. > 1.0

DESIGN FOR TORSION REQUIRED

$(2A_v A_f) \cot(\theta) / s =$
 $(2A_v A_f) \cot(\theta) / p_h =$
 $\phi T_u =$
 $T_u =$
DCR = 0.69 O.K.
 $A_f / s =$
 $A_{tr} = A_{wp} / s = A_v / s + 2A_f / s =$
 Check minimum torsion reinforcement required
 $0.75(\sqrt{f'_c}) b_w f_y =$
 $50 b_w f_y =$
 $A_{s,min} =$
 Try closed hoops with $A_{tr} / leg =$
 $S_R = 2A_v / 12 A_{tr} =$
 Check maximum spacing of shear reinforcement
 $S_{max} = d / 2 < 24"$ **O.K.**
 Check maximum spacing of torsion reinforcement
 $S_{max} = p_h / 8 < 12"$ **O.K.**

Torsional Strength

$A_{oh} = 464.1$ in²
 $A_o = 394.5$ in²
 $A_t = 0.6$ in²
 $s = 12$ in
 $\theta = 45$ degrees
 $A_t = 4.00$ in²
 $P_h = 89.5$ in
 $(2A_v A_f) \cot(\theta) / s = 197$ ft-kip
 $(2A_v A_f) \cot(\theta) / p_h = 176$ ft-kip
 $\phi T_u = 132$ ft-kip
 $T_u = 91$ ft-kip
DCR = 0.69 O.K.
 $A_f / s = 0.0500$
 0.1500 in²/in
 0.0237 in²/in
 0.0250 in²/in
 0.0250 in²/in
 0.3100 in²
 4.1333 in

Cross-sectional dimensions check

$V_u = 74.8$ kip
 $b_w = 30$ in
 $T_u = 91$ ft-kip
 $P_h = 89.5$ in
 $A_{oh} = 464.1$
 $V_c = 2\lambda \sqrt{f'_c} b_w d = 82$ kip
 $\sqrt{V_u (V_u / (b_w d))^2 + (T_u P_h / 1.7 A_{oh})^2} = 0.2909$ lb/in²
 $\phi = 0.75$
 $\phi(V_c b_w d + 8 \sqrt{f'_c}) = 474.34$ lb/in²
O.K.
 ACI 318-14,
 Equation 22.7.7.1a

Determine number of longitudinal bars required

No of peripheral longitudinal bars required = 14
 $(A_s)_{req'd} = (A_s)_{bot} + (A_s)_{top} + A_t = 12.00$ in²
 $(A_s)_{req'd} / (\text{No. bars}) = 0.86$
 Bar Size Required = **No. 9**
 Check minimum area of longitudinal reinforcement required
 $5 \sqrt{f'_c} A_{cp} f_y - (A_s) p_h (f_y / f_y) = -0.7053$
 $5 \sqrt{f'_c} A_{cp} f_y - (25 b_w f_y) p_h (f_y / f_y) = 3.7947$
 $A_{s,min} = 0.7053$
O.K.

CIDH PILE INTERACTION DIAGRAM:

Interaction Surface (ACI 318-14)

Edit

	P	M2	M3
1	-682.4719	0	0
2	-682.4719	0	560.0666
3	-632.9113	0	990.2579
4	-511.1714	0	1333.2658
5	-353.1888	0	1545.2535
6	-153.2484	0	1628.0755
7	-27.7201	0	1696.7365
8	140.0079	0	1525.1605
9	316.9694	0	744.9339
10	404.864	0	221.1981
11	432	0	0
12			
13			
14			
15			
16			
17			

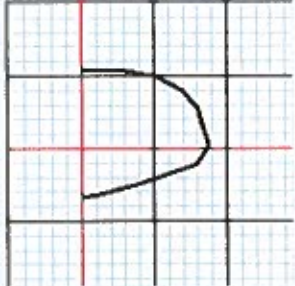
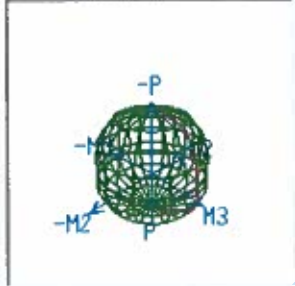
Design-Code Curve
 Fiber-Model Curve

Design Options

phi
 no phi
 no phi with fy increase

3D View

Plan: 315

Elevation: 35

3d MM PM3 PM2

Show Design-Code Results
 Show Fiber-Model Results

Done

Curve 1
Angle 0

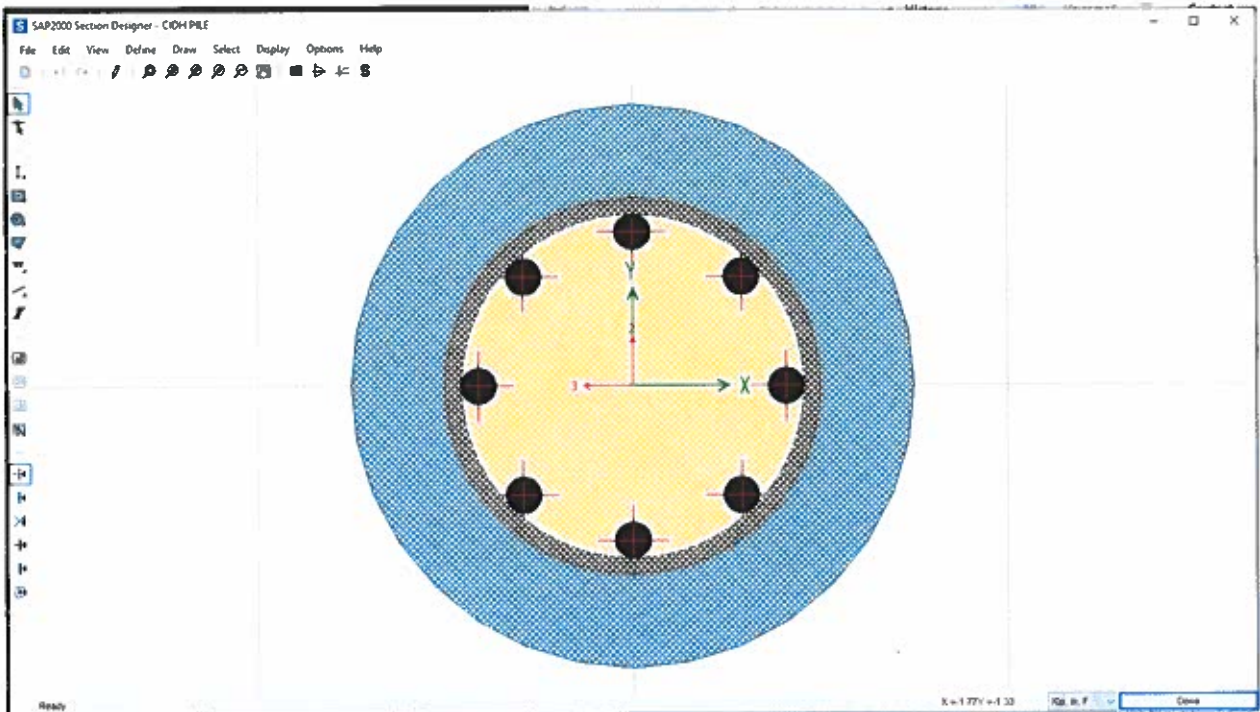

Client	Job Number	Sheet .. of
Project	Calcs by	Date
Subject	Checked by	Date

CIDH Pile Length

Per the attached allowable bearing capacity graph use 25' length for pile.

$$72^k \text{ compression} < 116^k \text{ comp allowable @ 25' embedment}$$

$$55^k \text{ Tension}^* < 67^k \text{ tens allowable @ 25' embedment}$$

* Tension on pile (uplift)
Tributary Dead Load to pile

$$\text{Wt of tank and contents} = \frac{4.56^k}{8.1818^\circ}$$

$$\text{Wt of pile cap} = 2.5(2')0.15^k/ft = 0.75^k/ft$$

$$S = r\theta = 35' \left(34^\circ \left(\frac{\pi}{180^\circ} \right) \right) = 20.77'$$

The tributary angular span to a pile is $\frac{34^\circ}{2} = 17^\circ$

$$\circ \circ (P_D)_{\text{tributary to pile}} = 17^\circ \left(\frac{4.56^k}{8.1818^\circ} \right) + 35' \left(17^\circ \left(\frac{\pi}{180^\circ} \right) \right) 0.75^k/ft = 17.3^k$$

$$\circ \circ \text{ The tension uplift} = 72^k - 17.3^k = 54.7^k \sim 55^k$$

Samoa - EQ Loading
 Allowable Vertical Capacity (kips)

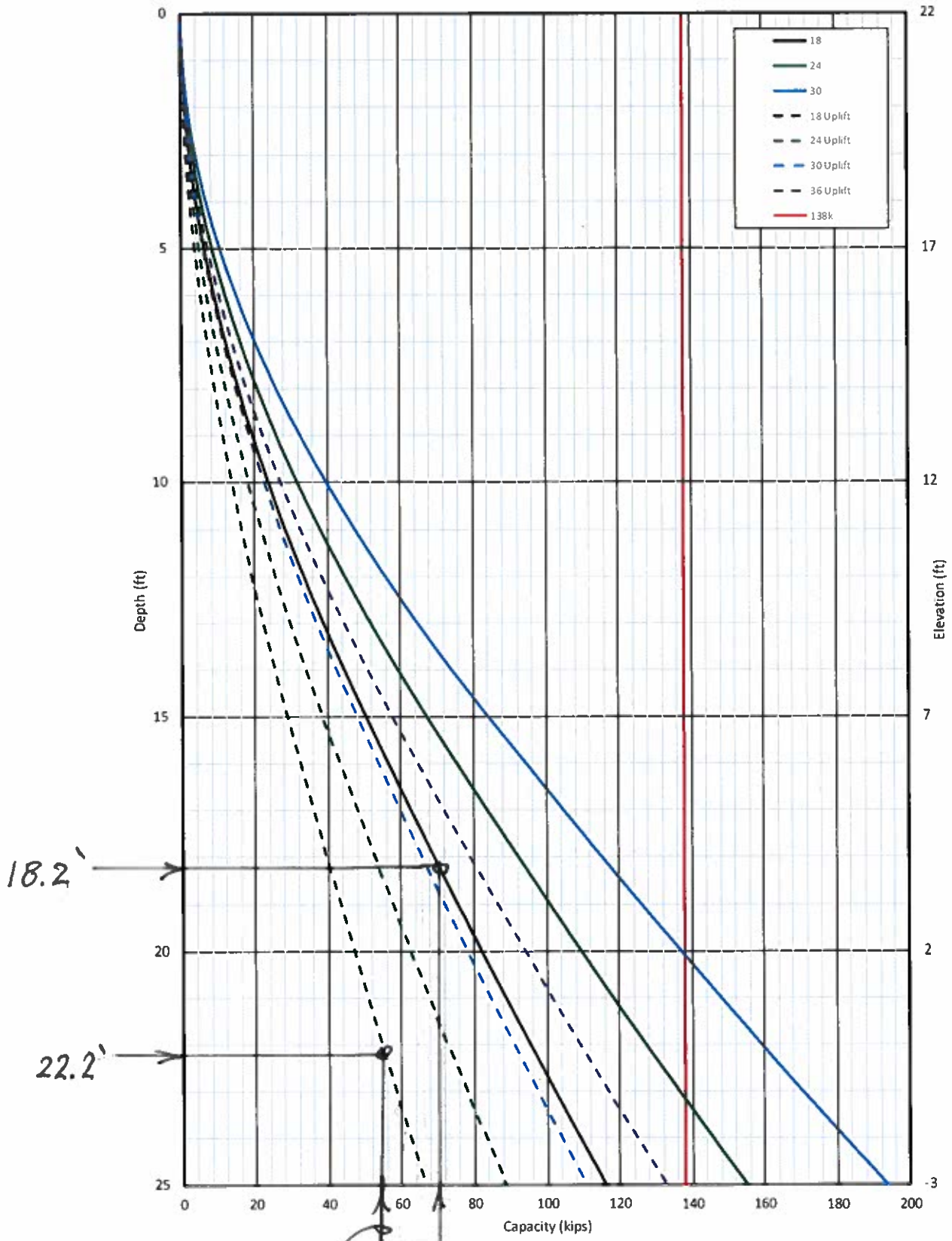

55^k Tens 72^k Comp
 Page 35 of 40

Client	Job Number	Sheet .. of ..
Project	Calcs by	Date
Subject	Checked by	Date

Headed Stud Design

Shear $V_u = 9.7 \text{ klt}$ (previously calculated)

Tension $V_u = 9.7 \text{ klt}$

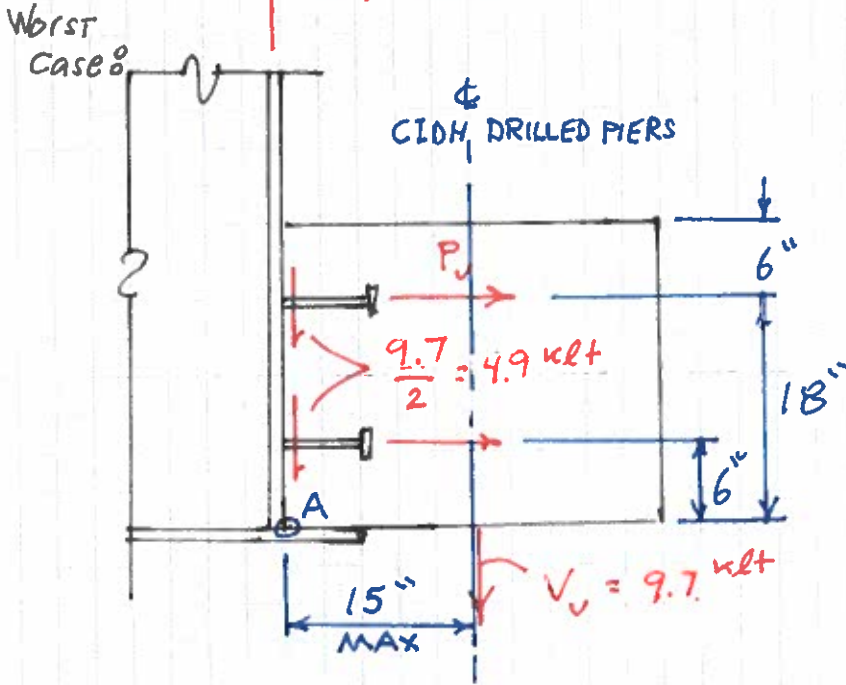

$M_A = 0$ Assume a linear distribution
 $P_u (18'') + \frac{1}{3} P_u (6'') = V_u (15'')$
 $P_u = 7.3 \text{ klt}$

Try 2 horizontal rows of $\frac{1}{2}$ H4L x $6\frac{1}{8}$ @ 6" O.C.

$1.2 > \frac{V_u}{\phi V_n} + \frac{P_u}{\phi P_n} = \frac{4.9 \text{ k}}{2(5.24 \text{ k})} + \frac{7.3 \text{ k}}{2(9.57 \text{ k})} = 0.47 + 0.38 = 0.85 < 1.2$ O.K.
 ACI 318-14, Equation 17.6.3 2 anchors per foot

6" O.C. > 4 ϕ_{STUD} = 2" \perp to shear
 12" O.C. > 6 ϕ_{STUD} = 3" \parallel to shear
 O.K.

■ **Headed Anchors**

Stock Sizes

D Stud Dia.	L Length	A	H	Part No.
1/4 H4L	3/4	0.187	0.500	102-053-031
	1 1/8			101-053-168
	2 11/16			101-053-031
	4 1/8			101-053-033
3/8 H4L	1 3/8	0.281	0.750	101-053-116
	1 5/8			101-053-107
	2 1/8			101-053-037
	2 5/8			101-053-039
	3 1/8			101-053-041
	4 1/8			101-053-043
	5 1/8			102-053-005
	6 1/8			101-053-045
1/2 H4L	2 1/8	0.312	1.000	101-053-047
	2 5/8			101-053-081
	3 1/8			101-053-002
	3 5/8			101-053-265
	4 1/8			101-053-003
	5 1/8			102-053-030
	5 5/16			101-053-005
	6 1/8			101-053-008
5/8 H4L	8 1/8	0.312	1.250	101-053-010
	1 7/16			101-053-331
	2 11/16			101-053-012
	3 3/16			101-053-014
	4 3/16			101-053-015
	5 3/16			101-053-064
	6 3/16			101-053-063
	6 9/16			101-053-019
3/4 S3L	8 3/16	0.375	1.250	101-053-023
	10 3/16			102-053-001
	3 3/16			101-098-003
	3 3/8			101-098-132
	3 7/8			101-098-127
	4 3/16			101-098-007
	4 7/8			101-098-131
	5 3/16			101-098-011
	5 3/8			101-098-143
	5 7/8			101-098-138
	6 3/16			101-098-015
	7 3/16			101-098-019
	8 3/16			101-098-023
	9 3/16			101-098-085
12 3/16	101-098-073			
7/8 S3L	14 3/16	0.375	1.375	101-098-025
	3 11/16			101-098-029
	4 3/16			101-098-031
	5 3/16			101-098-035
	5 11/16			101-098-037
	6 3/16			101-098-039
	6 11/16			101-098-087
	7 3/16			101-098-043
	8 3/16			101-098-047
	9 3/16			101-098-119
	10 1/32			101-098-007
1 S3L	12 3/16	0.500	1.625	101-098-066
	14 3/16			101-098-032
	4 1/4			101-098-204
	6 1/4			101-098-168
	8 1/4			101-098-177

H4L

S3L

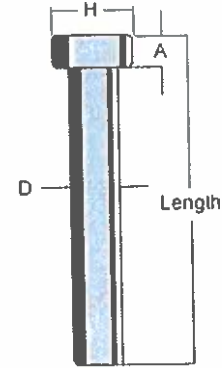

Physical Properties of H4L and S3L Anchors

Diameter	A _s Nominal Area	A _s f _y Yield Lbs. (min.)	A _s f _t Tensile Lbs. (min.)
1/4	0.049	2,405	2,994
3/8	0.110	5,632	7,179
1/2	0.196	10,014	12,763
5/8	0.307	15,647	19,942
3/4	0.442	22,531	28,716
7/8	0.601	30,667	39,086
1	0.785	40,055	51,051

f_t - Ultimate strength (tensile) - 65,000 psi min. (≥ 3/8" diam.)

f_y - Yield strength - 51,000 psi min. (≥ 3/8" diam.)

Elongation - 20% min. (≥ 3/8" diam.)

Reduction of area - 50% min.

Cold Finished low carbon steel.

ASTM A108: C - 0.23 max.

Mn - 0.90 max.

P - 0.040 max.

S - 0.050 max.

A - Area of stud shank

Tension Capacity

The following data are presented as guidelines only and based on embedded studs with adequate spacing for full capacity development. Appropriate safety factors should be applied based on actual use. For further information consult Nelson [Construction - Design Data](#).

Shear Capacity

Headed anchors embedded in concrete with an embedment length more than four times their diameter are capable of developing full shear capacity. Spacing is not as sensitive in shear as it is in tension. Spacing four times diameter between studs in a plane perpendicular to the shear force and six times diameter in the direction of the shear force is generally adequate to develop full stud capacity. Free edges in the direction of the shear force and some spacing restrictions along a free edge apply. Consult Nelson [Construction - Design Data](#) and use proper safety factors and edge reinforcement. An upper bound limit for headed studs is approached at 0.75 AsFs when concrete strength exceeds 5,000 psi. Headed studs used as inserts have different values than those employed in composite design. For shear capacity of studs in composite design with and without metal deck, see the AISC code and commentary dated June 2010 and [ACI 318, Appendix D, Anchoring to Concrete](#).

Short Form Specification
To insure that certified Nelson products are used, the following specification is suggested: "Headed anchors shall be Nelson type H4L or S3L, flux filled, welded to plates as shown on the drawings. Studs shall be made from cold-drawn steel Grades C-1010 through C-1020 per ASTM A-108 and welded pursuant to the manufacturer's recommendations."

H4L and S3L Tension Capacity in Concrete

(1.) Anchor Size	(2.) A.W. Length	D _s Head Diameter	Head Thickness	(3.) L _e	(4.) Factored Ultimate Strength of Anchor (φN _t) - kips	(5.) Factored Tension Capacity (φN _t) - kips									
						(6.)		(7.)			(8.)				
						f'c = 3000 psi NWT	f'c = 4000 psi NWT	f'c = 5000 psi NWT	f'c = 3000 psi SLWT	f'c = 4000 psi SLWT	f'c = 5000 psi SLWT	f'c = 3000 psi ALWT	f'c = 4000 psi ALWT	f'c = 5000 psi ALWT	
1/4 x 3/4	0.63	0.500	0.187	0.44	2.25	0.27	0.31	0.34	0.23	0.26	0.29	0.20	0.23	0.26	
1/4 x 1 1/8	1	0.500	0.187	0.81	2.25	0.67	0.78	0.87	0.57	0.66	0.74	0.51	0.58	0.65	
1/4 x 2 11/16	2.56	0.500	0.187	2.38	2.25	2.25	2.25	2.25	2.25	2.25	2.25	2.25	2.25	2.25	
1/4 x 4 1/8	4	0.500	0.187	3.81	2.25	2.25	2.25	2.25	2.25	2.25	2.25	2.25	2.25	2.25	
3/8 x 1 3/8	1.25	0.750	0.281	0.97	5.38	0.88	1.01	1.13	0.75	0.86	0.96	0.66	0.76	0.85	
3/8 x 1 5/8	1.5	0.750	0.281	1.22	5.38	1.24	1.43	1.60	1.05	1.22	1.36	0.93	1.07	1.20	
3/8 x 2 1/8	2	0.750	0.281	1.72	5.38	2.07	2.39	2.68	1.76	2.04	2.28	1.56	1.80	2.01	
3/8 x 2 5/8	2.5	0.750	0.281	2.22	5.38	3.04	3.51	3.93	2.59	2.99	3.34	2.28	2.63	2.95	
3/8 x 3 1/8	3	0.750	0.281	2.72	5.38	4.13	4.76	5.33	3.51	4.05	4.53	3.09	3.57	3.99	
3/8 x 4 1/8	4	0.750	0.281	3.72	5.38	5.38	5.38	5.38	5.38	5.38	5.38	4.95	5.38	5.38	
3/8 x 5 1/8	5	0.750	0.281	4.72	5.38	5.38	5.38	5.38	5.38	5.38	5.38	5.38	5.38	5.38	
3/8 x 6 1/8	6	0.750	0.281	5.72	5.38	5.38	5.38	5.38	5.38	5.38	5.38	5.38	5.38	5.38	
1/2 x 2 1/8	2	1.000	0.312	1.69	9.57	2.02	2.33	2.61	1.72	1.98	2.21	1.51	1.75	1.95	

(1.) Anchor Size	(2.) A.W. Length	D _s Head Diameter	Head Thickness	(3.) L _e	(4.) Factored Ultimate Strength of Anchor (φN _s) - kips	(5.) Factored Tension Capacity (φN _b) - kips									
						(6.)		(7.)			(8.)				
						f'c = 3000 psi NWT	f'c = 4000 psi NWT	f'c = 5000 psi NWT	f'c = 3000 psi SLWT	f'c = 4000 psi SLWT	f'c = 5000 psi SLWT	f'c = 3000 psi ALWT	f'c = 4000 psi ALWT	f'c = 5000 psi ALWT	
1/2 x 2 5/8	2.5	1.000	0.312	2.19	9.57	2.98	3.44	3.84	2.53	2.92	3.27	2.23	2.58	2.88	
1/2 x 3 1/8	3	1.000	0.312	2.69	9.57	4.06	4.68	5.24	3.45	3.98	4.45	3.04	3.51	3.93	
1/2 x 3 5/8	3.5	1.000	0.312	3.19	9.57	5.24	6.05	6.76	4.45	5.14	5.75	3.93	4.54	5.07	
1/2 x 4 1/8	4	1.000	0.312	3.69	9.57	6.52	7.53	8.41	5.54	6.40	7.15	4.89	5.64	6.31	
1/2 x 5 1/8	5	1.000	0.312	4.69	9.57	9.34	9.57	9.57	7.94	9.17	9.57	7.01	8.09	9.04	
1/2 x 5 5/8	5.19	1.000	0.312	4.88	9.57	9.57	9.57	9.57	8.42	9.57	9.57	7.43	8.58	9.57	
1/2 x 6 1/8	6	1.000	0.312	5.69	9.57	9.57	9.57	9.57	9.57	9.57	9.57	9.36	9.57	9.57	
1/2 x 8 1/8	8	1.000	0.312	7.69	9.57	9.57	9.57	9.57	9.57	9.57	9.57	9.57	9.57	9.57	
5/8 x 2 11/16	2.5	1.250	0.312	2.19	14.96	2.98	3.44	3.84	2.53	2.92	3.27	2.23	2.58	2.88	
5/8 x 4 3/16	4	1.250	0.312	3.69	14.96	6.52	7.53	8.41	5.54	6.40	7.15	4.89	5.64	6.31	
5/8 x 6 9/16	6.38	1.250	0.312	6.06	14.96	13.74	14.96	14.96	11.68	13.48	14.96	10.30	11.90	13.30	
5/8 x 8 3/16	8	1.250	0.312	7.69	14.96	14.96	14.96	14.96	14.96	14.96	14.96	14.71	14.96	14.96	
5/8 x 10 3/16	10	1.250	0.312	9.69	14.96	14.96	14.96	14.96	14.96	14.96	14.96	14.96	14.96	14.96	
3/4 x 2 3/16	2	1.250	0.375	1.63	21.54	1.91	2.20	2.46	1.62	1.87	2.09	1.43	1.65	1.85	
3/4 x 3 3/16	3	1.250	0.375	2.63	21.54	3.91	4.52	5.05	3.33	3.84	4.29	2.94	3.39	3.79	
3/4 x 3 3/8	3.19	1.250	0.375	2.81	21.54	4.34	5.01	5.60	3.69	4.26	4.76	3.26	3.76	4.20	
3/4 x 3 7/8	3.69	1.250	0.375	3.31	21.54	5.55	6.41	7.16	4.72	5.44	6.09	4.16	4.80	5.37	
3/4 x 4 3/16	4	1.250	0.375	3.63	21.54	6.35	7.33	8.20	5.40	6.23	6.97	4.76	5.50	6.15	
3/4 x 4 3/8	4.19	1.250	0.375	3.81	21.54	6.85	7.91	8.84	5.82	6.72	7.52	5.14	5.93	6.63	
3/4 x 4 7/8	4.69	1.250	0.375	4.31	21.54	8.24	9.52	10.64	7.00	8.09	9.04	6.18	7.14	7.98	
3/4 x 5 3/16	5	1.250	0.375	4.63	21.54	9.15	10.57	11.82	7.78	8.98	10.04	6.86	7.93	8.86	
3/4 x 5 3/8	5.19	1.250	0.375	4.81	21.54	9.71	11.22	12.54	8.26	9.53	10.66	7.29	8.41	9.41	
3/4 x 5 7/8	5.69	1.250	0.375	5.31	21.54	11.27	13.01	14.55	9.58	11.06	12.36	8.45	9.76	10.91	
3/4 x 6 3/16	6	1.250	0.375	5.63	21.54	12.28	14.18	15.85	10.43	12.05	13.47	9.21	10.63	11.89	
3/4 x 7 3/16	7	1.250	0.375	6.63	21.54	15.69	18.12	20.26	13.34	15.40	17.22	11.77	13.59	15.19	
3/4 x 8 3/16	8	1.250	0.375	7.63	21.54	19.37	21.54	21.54	16.47	19.02	21.26	14.53	16.78	18.76	
3/4 x 9 3/16	9	1.250	0.375	8.63	21.54	21.54	21.54	21.54	19.81	21.54	21.54	17.48	20.19	21.54	
3/4 x 10 3/16	10	1.250	0.375	9.63	21.54	21.54	21.54	21.54	21.54	21.54	21.54	20.61	21.54	21.54	
3/4 x 12 3/16	12	1.250	0.375	11.63	21.54	21.54	21.54	21.54	21.54	21.54	21.54	21.54	21.54	21.54	
7/8 x 3 11/16	3.5	1.375	0.375	3.13	29.31	5.08	5.87	6.56	4.32	4.99	5.58	3.81	4.40	4.92	
7/8 x 4 3/16	4	1.375	0.375	3.63	29.31	6.35	7.33	8.20	5.40	6.23	6.97	4.76	5.50	6.15	
7/8 x 5 3/16	5	1.375	0.375	4.63	29.31	9.15	10.57	11.82	7.78	8.98	10.04	6.86	7.93	8.86	
7/8 x 5 11/16	5.5	1.375	0.375	5.13	29.31	10.68	12.33	13.78	9.07	10.48	11.72	8.01	9.25	10.34	
7/8 x 6 3/16	6	1.375	0.375	5.63	29.31	12.28	14.18	15.85	10.43	12.05	13.47	9.21	10.63	11.89	
7/8 x 6 11/16	6.5	1.375	0.375	6.13	29.31	13.95	16.11	18.01	11.86	13.69	15.31	10.46	12.08	13.51	
7/8 x 7 3/16	7	1.375	0.375	6.63	29.31	15.69	18.12	20.26	13.34	15.40	17.22	11.77	13.59	15.19	
7/8 x 8 3/16	8	1.375	0.375	7.63	29.31	19.37	22.37	25.01	16.47	19.02	21.26	14.53	16.78	18.76	
7/8 x 9 3/16	9	1.375	0.375	8.63	29.31	23.31	26.91	29.31	19.81	22.88	25.58	17.48	20.19	22.57	
7/8 x 10 1/32	9.84	1.375	0.375	9.47	29.31	26.81	29.31	29.31	22.79	26.31	29.31	20.11	23.22	25.96	
7/8 x 12 3/16	12	1.375	0.375	11.63	29.31	29.31	29.31	29.31	29.31	29.31	29.31	27.67	29.31	29.31	
7/8 x 14 3/16	14	1.375	0.375	13.63	29.31	29.31	29.31	29.31	29.31	29.31	29.31	29.31	29.31	29.31	
1 x 4 1/4	4	1.625	0.5	3.50	38.29	6.03	6.96	7.78	5.12	5.91	6.61	4.52	5.22	5.83	
1 x 6 1/4	6	1.625	0.5	5.50	38.29	11.87	13.71	15.32	10.09	11.65	13.02	8.90	10.28	11.49	
1 x 8 1/4	8	1.625	0.5	7.50	38.29	18.90	21.82	24.40	16.07	18.55	20.74	14.18	16.37	18.30	

Notes:

- (1) Stock anchor size.
- (2) A.W. = Length overall after welding.
- (3) L_e = Length of embedment under head of anchor. Ignores thickness of an embedment plate which will increase L_e.
- (4) φN_s = 0.75A_sf_s.

- (5) φN_b = 0.70k₁k₂k₃k₄k₅ where φN_b = φN_s. φN_b governs as φN_s. Assumes no supplemental reinforcement. Pullout and side face blowout strengths not considered.
- (6) NWT = normal weight concrete (λ = 1.0).
- (7) SLWT = sand lightweight concrete (λ = 0.85).
- (8) ALWT = All lightweight concrete (λ = 0.75).

H4L and S3L Shear Capacity in Concrete

(1.) Anchor Size	(2.) A.W. Length	IDs (No. of Diam.)	(3.) Factored Steel Shear Strength (ϕV_s) - kips	(4.) (5.) Factored Shear Breakout Capacity (ϕV_b) - kips								
				(6.)			(7.)			(8.)		
				$f'c = 3000$ psi NWT	$f'c = 4000$ psi NWT	$f'c = 5000$ psi NWT	$f'c = 3000$ psi SLWT	$f'c = 4000$ psi SLWT	$f'c = 5000$ psi SLWT	$f'c = 3000$ psi ALWT	$f'c = 4000$ psi ALWT	$f'c = 5000$ psi ALWT
1/4 x 3/4	0.63	1.75	1.95	1.95	1.95	1.95	1.88	1.95	1.95	1.65	1.91	1.95
1/4 x 1 1/8	1	3.25	1.95	1.95	1.95	1.95	1.95	1.95	1.95	1.87	1.95	1.95
1/4 x 2 11/16	2.56	9.50	1.95	1.95	1.95	1.95	1.95	1.95	1.95	1.95	1.95	1.95
1/4 x 4 1/8	4	15.25	1.95	1.95	1.95	1.95	1.95	1.95	1.95	1.95	1.95	1.95
3/8 x 1 3/8	1.25	2.58	4.67	2.92	3.37	3.77	2.48	2.87	3.20	2.19	2.53	2.83
3/8 x 1 5/8	1.5	3.25	4.67	3.06	3.53	3.95	2.60	3.00	3.36	2.29	2.65	2.96
3/8 x 2 1/8	2	4.58	4.67	3.28	3.78	4.23	2.78	3.21	3.59	2.46	2.84	3.17
3/8 x 2 5/8	2.5	5.92	4.67	3.45	3.98	4.45	2.93	3.38	3.78	2.59	2.99	3.34
3/8 x 3 1/8	3	7.25	4.67	3.59	4.15	4.63	3.05	3.52	3.94	2.69	3.11	3.48
3/8 x 4 1/8	4	9.92	4.67	3.82	4.41	4.67	3.25	3.75	4.19	2.87	3.31	3.70
3/8 x 5 1/8	5	12.58	4.67	4.01	4.63	4.67	3.41	3.93	4.40	3.01	3.47	3.88
3/8 x 6 1/8	6	15.25	4.67	4.17	4.67	4.67	3.54	4.09	4.57	3.12	3.61	4.03
1/2 x 2 1/8	2	3.38	8.30	3.56	4.11	4.59	3.02	3.49	3.90	2.67	3.08	3.44
1/2 x 2 5/8	2.5	4.38	8.30	3.75	4.33	4.84	3.18	3.68	4.11	2.81	3.24	3.63
1/2 x 3 1/8	3	5.38	8.30	3.90	4.51	5.04	3.32	3.83	4.28	2.93	3.38	3.78
1/2 x 3 5/8	3.5	6.38	8.30	4.04	4.66	5.22	3.43	3.97	4.43	3.03	3.50	3.91
1/2 x 4 1/8	4	7.38	8.30	4.16	4.80	5.37	3.54	4.08	4.56	3.12	3.60	4.03
1/2 x 5 1/8	5	9.38	8.30	4.36	5.04	5.63	3.71	4.28	4.79	3.27	3.78	4.23
1/2 x 5 5/16	5.19	9.75	8.30	4.40	5.08	5.68	3.74	4.32	4.83	3.30	3.81	4.26
1/2 x 6 1/8	6	11.38	8.30	4.54	5.24	5.86	3.86	4.45	4.98	3.40	3.93	4.39
1/2 x 8 1/8	8	15.38	8.30	4.82	5.56	6.22	4.10	4.73	5.29	3.61	4.17	4.66
5/8 x 2 11/16	2.5	3.50	12.96	4.01	4.63	5.17	3.41	3.93	4.40	3.00	3.47	3.88
5/8 x 4 3/16	4	5.90	12.96	4.45	5.14	5.74	3.78	4.37	4.88	3.34	3.85	4.31
5/8 x 6 9/16	6.38	9.70	12.96	4.91	5.67	6.34	4.18	4.82	5.39	3.68	4.25	4.76
5/8 x 8 3/16	8	12.30	12.96	5.07	5.86	6.55	4.31	4.98	5.57	3.80	4.39	4.91
5/8 x 10 3/16	10	15.50	12.96	5.07	5.86	6.55	4.31	4.98	5.57	3.80	4.39	4.91
3/4 x 2 3/16	2	2.17	18.67	3.99	4.60	5.15	3.39	3.91	4.38	2.99	3.45	3.86
3/4 x 3 3/16	3	3.50	18.67	4.39	5.07	5.67	3.73	4.31	4.82	3.29	3.80	4.25
3/4 x 3 3/8	3.19	3.75	18.67	4.45	5.14	5.74	3.78	4.37	4.88	3.34	3.85	4.31
3/4 x 3 7/8	3.69	4.42	18.67	4.60	5.31	5.94	3.91	4.51	5.05	3.45	3.98	4.45
3/4 x 4 3/16	4	4.83	18.67	4.68	5.41	6.04	3.98	4.59	5.14	3.51	4.05	4.53
3/4 x 4 3/8	4.19	5.08	18.67	4.73	5.46	6.10	4.02	4.64	5.19	3.55	4.10	4.58
3/4 x 4 7/8	4.69	5.75	18.67	4.85	5.60	6.26	4.12	4.76	5.32	3.64	4.20	4.69
3/4 x 5 3/16	5	6.17	18.67	4.92	5.68	6.35	4.18	4.82	5.39	3.69	4.26	4.76
3/4 x 5 3/8	5.19	6.42	18.67	4.95	5.72	6.40	4.21	4.86	5.44	3.72	4.29	4.80
3/4 x 5 7/8	5.69	7.08	18.67	5.05	5.83	6.52	4.30	4.96	5.55	3.79	4.38	4.89
3/4 x 6 3/16	6	7.50	18.67	5.11	5.90	6.60	4.34	5.02	5.61	3.83	4.43	4.95
3/4 x 7 3/16	7	8.83	18.67	5.28	6.10	6.82	4.49	5.18	5.80	3.96	4.57	5.11
3/4 x 8 3/16	8	10.17	18.67	5.43	6.27	7.01	4.62	5.33	5.96	4.07	4.70	5.26
3/4 x 9 3/16	9	11.50	18.67	5.57	6.43	7.19	4.73	5.46	6.11	4.18	4.82	5.39
3/4 x 10 3/16	10	12.83	18.67	5.69	6.57	7.35	4.84	5.59	6.24	4.27	4.93	5.51
3/4 x 12 3/16	12	15.50	18.67	5.91	6.82	7.63	5.02	5.80	6.49	4.43	5.12	5.72
7/8 x 3 11/16	3.5	3.57	25.41	4.76	5.50	6.14	4.05	4.67	5.22	3.57	4.12	4.61
7/8 x 4 3/16	4	4.14	25.41	4.90	5.66	6.33	4.17	4.81	5.38	3.68	4.25	4.75
7/8 x 5 3/16	5	5.29	25.41	5.07	5.86	6.55	4.31	4.98	5.57	3.80	4.39	4.91
7/8 x 6 3/16	5.5	5.86	25.41	5.07	5.86	6.55	4.31	4.98	5.57	3.80	4.39	4.91
7/8 x 7 3/16	6	6.43	25.41	5.07	5.86	6.55	4.31	4.98	5.57	3.80	4.39	4.91
7/8 x 8 3/16	6.5	7.00	25.41	5.07	5.86	6.55	4.31	4.98	5.57	3.80	4.39	4.91
1 x 4 1/4	7	7.57	25.41	5.07	5.86	6.55	4.31	4.98	5.57	3.80	4.39	4.91
1 x 6 1/4	8	8.71	25.41	5.07	5.86	6.55	4.31	4.98	5.57	3.80	4.39	4.91
1 x 8 1/4	9	9.86	25.41	5.07	5.86	6.55	4.31	4.98	5.57	3.80	4.39	4.91

Notes:

(1.) Stock anchor size.

(2.) A.W. = Length overall after welding.

(3.) $\phi V_s = 0.65 A_s f_y$

(4.) $\phi V_b = 0.70 A_c \sqrt{f'c} \sqrt{e/D_a} \exp(0.2 \sqrt{f'c}) \sqrt{e/D_a} \sqrt{f'c}$ (edge distance $\geq 1.5l$), where $l = e/D_a \geq 8$ alternately (if less)

$\phi V_b = 0.70 A_c \sqrt{f'c} \sqrt{e/D_a}$ (edge distance $\leq 1.5l$). Where $\phi V_b / \phi V_s \leq 1.5$. Assumes no supplemental reinforcement. Pryout strength not considered.

(5.) A 1/2 inches edge distance perpendicular to load is assumed.

(6.) NWT = normal weight concrete ($\lambda = 1.0$).

(7.) SLWT = sand light weight concrete ($\lambda = 0.85$).

(8.) ALWT = All light weight concrete ($\lambda = 0.75$).

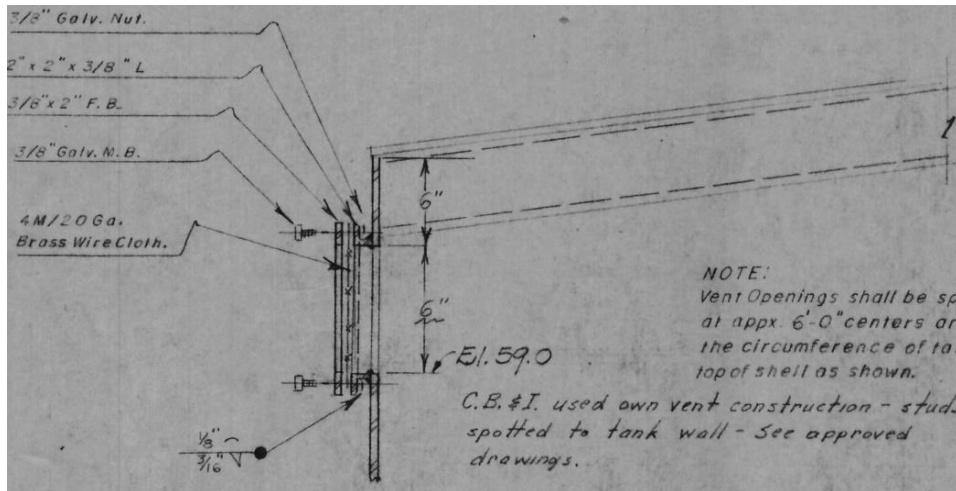

NOTE:
 Vent Openings shall be spaced
 at appx. 6'-0" centers around
 the circumference of tank at
 top of shell as shown.

C.B. & I. used own vent construction - studs
 spotted to tank wall - See approved
 drawings.

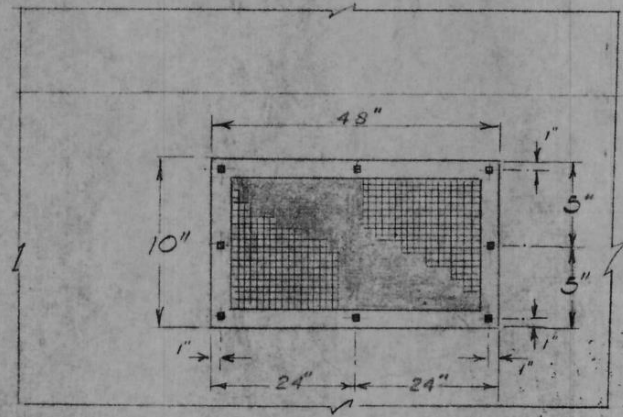

CIRCUMFERENTIAL VENT SCREEN DETAIL